

**Call to Order:**

The meeting was called to order by Chair Zets at 3:35 p.m.

**Roll Call:**

Brian Zets, Chair	P
Victor Wilson, Vice Chair	P
Bill Resch, Secretary	P
Nancy Ferguson	P
Thomas Shockey	P
Mary Fee	A
Bill Carleton	P

Staff members present: Jennifer Mason, Clerk of Council, and Mark Nemeč, Public Service Director.

**Approval of the November 13, 2019 meeting minutes:**

Chair Zets asked if there were any changes to the proposed minutes. Hearing none, Member Carleton moved to approve the November 13, 2019 minutes. Secretary Resch seconded. All members voted to approve the November 13, 2019 meeting minutes.

**Approval of the Agenda:**

Chair Zets asked if there were any proposed changes to the agenda. Hearing none, Chair Zets moved to approve the agenda. Secretary Resch seconded and all members voted to approve the agenda.

**Hearing of Visitors:**

None.

**Discussion of Historical Marker Text:**

Members discussed the text and made suggestions for changes per the attached document. After the changes were made, Clerk Mason said she would send a revision of the text out to the CRAB ahead of the next meeting.

**Other Business:**

Chair Zets told members about speaking with Reporter Sarah Sole for the article on Wagner Cemetery. One correction was made after the article's publication clarifying that the \$45,000 price was to restore all 145 of the monuments.

Members discussed the fencing surrounding the Wagner Cemetery. Member Carleton obtained the attached quote from Able Fence of Columbus. Previous CRAB member David Cline had sent an email recounting his positive experience with Able.

Member Carlton clarified that the Able Fence quote was for all four sides plus a walk-in gate. No brick or other pillars were included. Members discussed whether the fencing should match that of Maplewood Cemetery. Members favored a 10 foot drive-in swinging gate to bring in equipment. State tax was not applicable to city projects. Member Ferguson stated that City Manager Stefanov could solicit additional quotes. Director Nemecek stated that he would follow up about whether prevailing wages, as mentioned in the quote, would be applicable, and he would reach out to Rocky Fork Company with this bid but with the price removed.

Member Shockey told the CRAB that Clairibell Harlan lived in the house behind Wagner Cemetery. She was in her 90s. It would probably be best if the city communicated with her before work began.

Member Ferguson turned the topic to the city's website for the New Albany Cemetery. She volunteered to start an outline of potential webpages. Vice Chair Wilson suggested looking at other cemetery websites for ideas. Topics ideas from members included the following.

- CRAB Report
- Final list of names – family tree format? – searchable?
- Who is CRAB? What did they do?
- Detail Ohio Valley Archaeology work
- Mark Smith's restoration process
- Links to Township cemeteries – "These two cemeteries that the city maintains are not the only ones. You can search these other cemeteries."
- Pictures – separate page?

Members Ferguson and Carleton talked about needing the list of those interred both in the New Albany Cemetery and the Wagner Cemetery. Mark Smith could have a list for Wagner Cemetery. Vice Chair Wilson asked if the New Albany Plain Township Historical Society should be more involved. Member Ferguson offered that three members of the CRAB were members of the Historical Society and that, currently, the organization was more focused on programming. Clerk Mason said she would email the topic suggestions to Member Ferguson after this meeting.

**Schedule the next meeting:**

The next meeting was scheduled for Wednesday, February 12, 2020 at 3:30 p.m. at Village Hall.

**Poll members for comment:**

None.

**Adjournment:**

Chair Zets moved and Vice Chair Wilson seconded to adjourn. The meeting was adjourned at 4:38 p.m.

Signed:

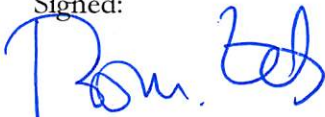

Brian Zets, Chair



Bill Resch, Secretary

Date

2/12/20

FRONT

① The New Albany Cemetery was created in 1854 and 1855 from the sale of three parcels, totaling 0.568 acres, owned by William Yantis, Jesse Kohn, and Elizabeth Arnold. This cemetery is the burial place of New Albany's founders, their families, and many of New Albany's earliest residents. <sup>Land</sup> ② 0.568 acre

Because Rose Run Creek often flooded, water from the creek frequently washed into the New Albany Cemetery. Realizing a better location was needed, Maplewood Cemetery was created a short distance south of here in 1881. Approximately 19 people were re-interred from the New Albany Cemetery. The New Albany Cemetery was no longer utilized. ③ ④ To Maplewood ⑤ Not long after;

By 1970, the New Albany Cemetery had become neglected. Monuments were missing and no reliable records existed for the individuals buried in the cemetery. ⑥ ⑦

(124 words)

BACK

In 1979, the New Albany-Plain Township Local Historical Society retrieved 25 monuments. The Franklin County Genealogical Society recorded the names. ⑧ several ⑨ from the creek ⑩ all visible

In 2015, the New Albany Cemetery Restoration Advisory Board was formed to restore the cemetery. After extensive research and geographic imaging, the Board determined 134 individuals were originally interred in the New Albany Cemetery. The oldest headstone dates from 1837, predating the founding of the cemetery. ⑪ here ⑫

By 2018, the Advisory Board identified the names of 68 individuals buried in the cemetery.

While several headstones were cleaned and reset, the remaining headstones were repaired and placed carefully where no existing gravesites were located. Twelve additional headstones were reproduced because the originals were not restorable or missing.

(115 words)

# Proposal

Page No. 1 OF 2

ABLE FENCE OF COLUMBUS, INC.  
2779 East 4th Avenue  
Columbus, OH 43219

Phone: (614) 253-8587 Fax: (614) 253-8598

Proposal Submitted To: <i>City of New Albany</i>	Tele <i>614 855 3913</i>	DATE: <i>11-21-19</i>
Address: <i>99 W. Main St.</i>	Project Name: <i>Cemetery - Central College</i>	
City, State, & Zip: <i>New Albany, OH 43054</i>	Attn.: <i>Bill</i>	

We hereby submit specifications and estimates for:

Furnish and install 608 LF +/- of 4'H steel ornamental fence and (1) 10'W double swing gate using material by Ameristar per page 2 of 2. Includes removal and disposal of existing fence

- Excludes state use tax (add \$1515.00 if applicable) and any necessary clearing
- Based on merit/shop wages (prevailing wages, if applicable, add \$4170.00)

We Propose hereby to furnish material and labor - complete in accordance with above specifications for the sum of **\$33,873-**  
Payment to be made as follows: *Net 30*

Property owner is solely responsible for locating, staking, & clearing fence lines and locating any underground obstructions or utilities.

**LIMITED WARRANTY- LIMITATION OF LIABILITY:** For a period of one year after installation, Able warrants that the products sold hereunder shall be free from defects and workmanship. The aforesaid warranty by Able is the sole warranty hereunder. **THERE IS NO WARRANTY THAT THE PRODUCTS SOLD HEREUNDER WILL BE MERCHANTABLE OR FIT FOR ANY PARTICULAR PURPOSE, NOR IS THERE ANY OTHER WARRANTY, EXPRESS OR IMPLIED, EXCEPT AS IS EXPRESSLY STATED IN THIS PARAGRAPH.** Able shall in no event be liable to the purchaser, or to a person who shall purchase from the purchaser, for damages of any kind, including, but not limited to, direct, indirect, special or consequential damages or claims of third parties, resulting from any cause whatsoever, and the sole liability of Able hereunder for any cause of action, whether based on negligence, contract or strict liability, shall be to repair or replace any defective products. In the event products sold hereunder by Able are manufactured by a third party, Able hereby assigns to purchaser all of the warranty rights which Able obtained as a result of the purchase of such terms from the third party.

All material is guaranteed to be as specified. All work to be completed in a workmanlike manner according to standard practices. Any alteration or deviation from above specifications involving extra costs will be executed only upon written orders, and will become an extra charge over and above the estimate. All agreements contingent upon strikes, accidents or delays beyond our control. Owner to carry fire, tornado and other necessary insurance. Our workers are fully covered by Worker's Compensation Insurance.

Authorized Signature

*Michael Heffernan*

Note: Proposal is valid for **30** days.

Acceptance of Proposal - The above prices, specifications and conditions are satisfactory and are hereby accepted. You are authorized to do the work as specified. Payment will be made as outlined above.

Signature \_\_\_\_\_

Print Name / Title \_\_\_\_\_

Date of Acceptance \_\_\_\_\_

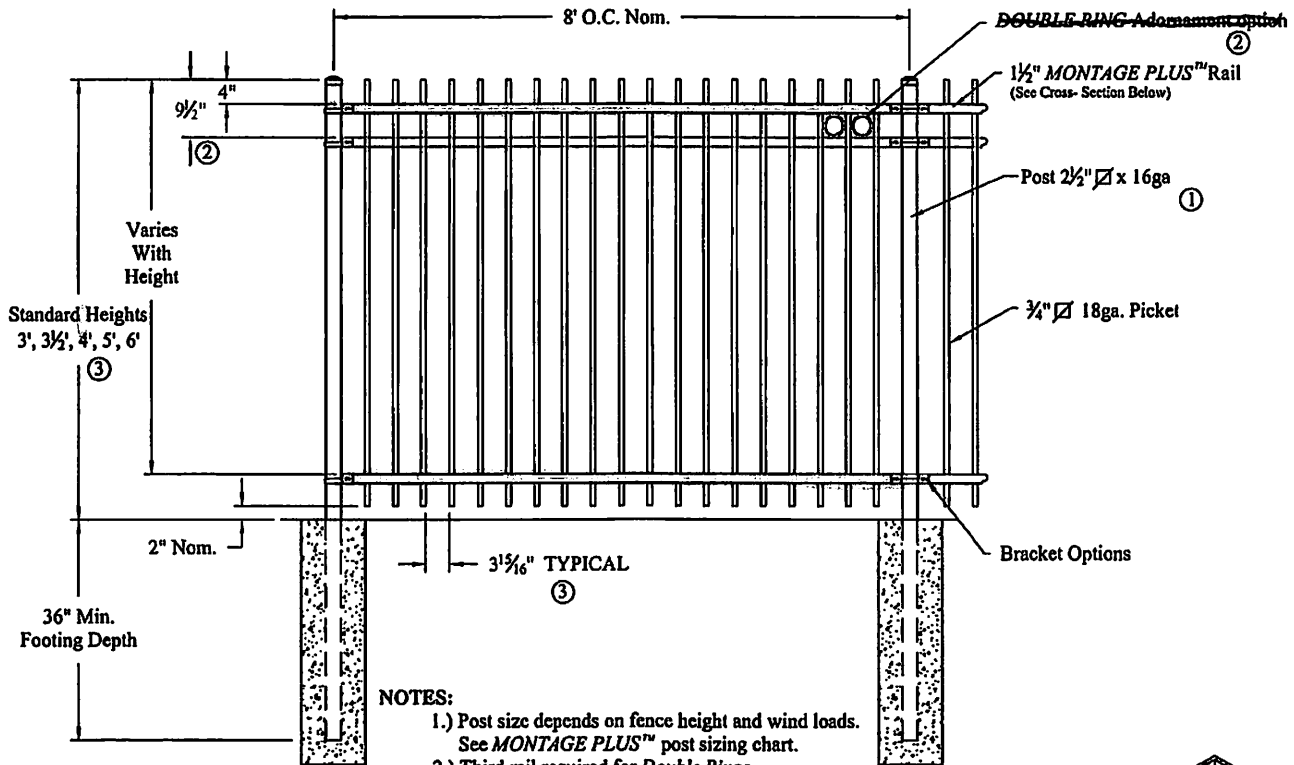

**NOTES:**

- 1.) Post size depends on fence height and wind loads. See MONTAGE PLUS™ post sizing chart.
- 2.) Third rail required for Double Rings.
- 3.) Available in 3" air space and/or Flush Bottom on most heights.

**RAKING DIRECTIONAL ARROW**  
 Welded panel can be raked 30" over 8' with arrow pointing down grade.

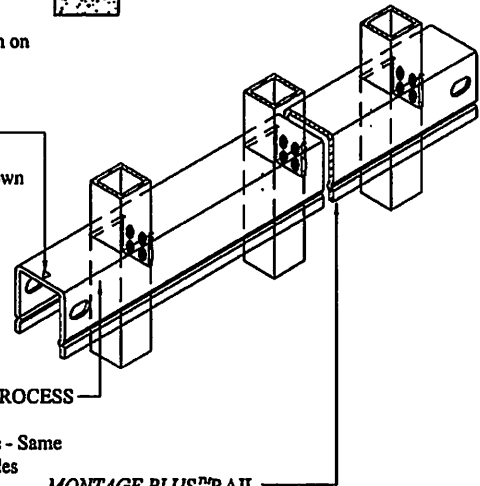

**PROFUSION™ WELDING PROCESS**  
 No exposed welds, Good Neighbor profile - Same appearance on both sides

**MONTAGE PLUS™ RAIL**  
 Specially formed high strength architectural shape.

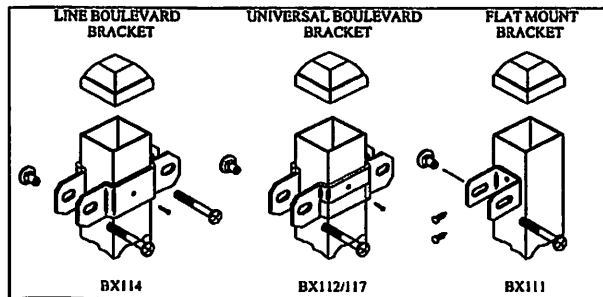
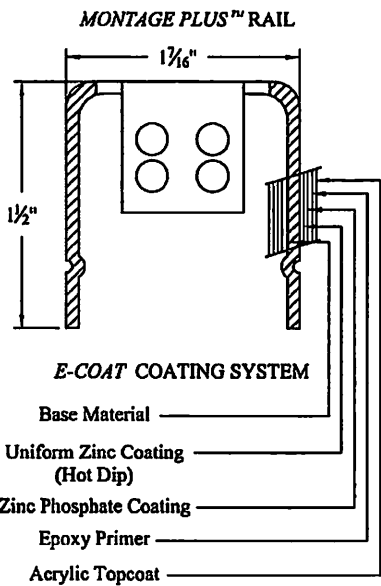

**COMMERCIAL STRENGTH WELDED STEEL PANEL**  
**PRE-ASSEMBLED**

Values shown are nominal and not to be used for installation purposes. See product specification for installation requirements.

IRGISO

Title: <b>MONTAGE PLUS GENESIS 2 1/8" RAIL</b>			
DR: CI	SH. 1 of 1	SCALE: DO NOT SCALE	
CK: ME	Date 6/28/10	REV: e	



**AMERISTAR®**

1555 N. Mingo  
 Tulsa, OK 74116  
 1-888-333-3422  
 www.ameristarfence.com