



**ORDINANCE O-08-2026**

**AN ORDINANCE PROVIDING FOR THE ISSUANCE AND SALE OF NOTES IN THE MAXIMUM PRINCIPAL AMOUNT OF \$10,000,000, IN ANTICIPATION OF THE ISSUANCE OF BONDS, FOR THE PURPOSE OF PAYING THE COSTS OF IMPROVING THE CITY'S VEHICULAR TRANSPORTATION SYSTEM, AND DECLARING AN EMERGENCY**

**WHEREAS**, pursuant to Ordinance No. O-34-2025 adopted August 5, 2025, notes in anticipation of bonds in the principal amount of \$14,965,000, dated September 9, 2025 (the "*Outstanding Notes*"), were issued for the purpose stated in Section 1, to mature on June 4, 2026; and

**WHEREAS**, this City Council finds and determines that the City should retire the Outstanding Notes with the proceeds of the Notes described in Section 3 and other funds available to the City; and

**WHEREAS**, this City Council has requested that the Director of Finance, as fiscal officer of this City, certify the estimated life or period of usefulness of the Improvement described in Section 1, the estimated maximum maturity of the Bonds described in Section 1 and the maximum maturity of the Notes described in Section 3 to be issued in anticipation of the Bonds; and

**WHEREAS**, the Director of Finance has certified to this City Council that the estimated life or period of usefulness of the Improvement described in Section 1 is at least five (5) years, the estimated maximum maturity of the Bonds described in Section 1 is at least twenty (20) years, and the maximum maturity of the Notes described in Section 3, to be issued in anticipation of the Bonds, is September 11, 2044; and

**WHEREAS**, this Ordinance constitutes an emergency measure necessary for the immediate preservation of the public peace, health, safety or welfare of the City, and for the further reason that this Ordinance is required to be immediately effective in order to permit the prompt issuance of the Notes, which is necessary to enable the City to timely retire the Outstanding Notes and thereby approve its credit.

**NOW, THEREFORE, BE IT ORDAINED** by Council for the City of New Albany, Counties of Franklin and Licking, State of Ohio, that:

**Section 1.** Authorized Principal Amount of Anticipated Bonds; Purpose. It is necessary to issue bonds of this City in the maximum principal amount of \$10,000,000 (the "*Bonds*") for the purpose of paying the costs of improving the City's vehicular transportation system, including Briscoe Parkway, the Market Street extension, Third Street, Reynoldsburg-New Albany Road and U.S. Route 62/Main Street, by constructing, reconstructing, extending, opening, widening, grading, draining, curbing, paving and resurfacing, including erosion controls, tree clearing and site preparation, installing or relocating sanitary sewer, storm sewer and water improvements, signage and striping, streetlighting

and signalization, electrical and telecommunications duct banks, turn lanes, sidewalks, crosswalks and bikeways, ADA curb ramps, streetscaping, landscaping and other aesthetic improvements, and acquiring interests in real estate therefor, together with all incidental work and related appurtenances thereto (the “*Improvement*”).

**Section 2.** Estimated Bond Terms. The Bonds shall be dated approximately June 1, 2027, shall bear interest at the now estimated rate of 6.00% per year, payable semiannually until the principal amount is paid, and are estimated to mature in twenty (20) annual principal installments on December 1 of each year and in such amounts that the total principal and interest payments on the Bonds, in any fiscal year in which principal is payable, shall be substantially equal. The first principal payment on the Bonds is estimated to be December 1, 2027.

**Section 3.** Authorized Principal Amount of Notes; Dating; Interest Rate. It is necessary to issue and this City Council determines that notes in the maximum principal amount of \$10,000,000 (the “*Notes*”) shall be issued in anticipation of the issuance of the Bonds for the purpose described in Section 1 and to retire, together with other funds available to the City, the Outstanding Notes and to pay any financing costs. The principal amount of Notes to be issued (not to exceed the stated maximum principal amount) shall be determined by the Director of Finance in the certificate awarding the Notes in accordance with Section 6 of this Ordinance (the “*Certificate of Award*”) as the amount which, along with other available funds of the City, is necessary to provide for the retirement of the Outstanding Notes and to pay any financing costs. The Notes shall be dated the date of issuance and shall mature not more than one year following the date of issuance, *provided* that the Director of Finance shall establish the maturity date in the Certificate of Award. The Notes shall bear interest at a rate or rates not to exceed 6.50% per year (computed on the basis of a 360-day year consisting of twelve 30-day months), payable at maturity and until the principal amount is paid or payment is provided for. The rate or rates of interest on the Notes shall be determined by the Director of Finance in the Certificate of Award in accordance with Section 6 of this Ordinance.

**Section 4.** Payment of Debt Charges; Paying Agent. The debt charges on the Notes shall be payable in lawful money of the United States of America or in Federal Reserve funds of the United States of America as determined by the Director of Finance in the Certificate of Award, and shall be payable, without deduction for services of the City’s paying agent, at the office of a bank or trust company designated by the Director of Finance in the Certificate of Award after determining that the payment at that bank or trust company will not endanger the funds or securities of the City and that proper procedures and safeguards are available for that purpose or at the office of the Director of Finance if agreed to by the Director of Finance and the original purchaser (the “*Paying Agent*”).

The City Manager and the Director of Finance shall sign and deliver, in the name and on behalf of the City, the Note Registrar Agreement between the City and the Paying Agent, in substantially the form as is now on file with the Clerk of Council. The Note Registrar Agreement is approved, together with any changes or amendments that are not inconsistent with this Ordinance and not substantially adverse to the City and that are approved by the City Manager and the Director of Finance on behalf of the City, all of which shall be conclusively evidenced by the signing of the Note Registrar Agreement or amendments thereto. The Director of Finance shall provide for the payment of the services rendered and for reimbursement of expenses incurred pursuant to the Note Registrar Agreement, except to the extent paid or reimbursed by the original purchaser and/or the Paying Agent in accordance with the Certificate of Award, from the proceeds of the Notes to the extent available and then from other money lawfully available and appropriated or to be appropriated for that purpose.

**Section 5. Execution of Notes; Book-Entry System.** The Notes shall be signed by the City Manager and the Director of Finance, in the name of the City and in their official capacities; *provided* that one of those signatures may be a facsimile. The Notes shall be issued in minimum denominations of \$100,000 (and may be issued in denominations in such amounts in excess thereof as requested by the original purchaser and approved by the Director of Finance) and with numbers as requested by the original purchaser and approved by the Director of Finance. The entire principal amount may be represented by a single note and may be issued as fully registered securities (for which the Director of Finance will serve as note registrar) and in book entry or other uncertificated form in accordance with Section 9.96 and Chapter 133 of the Ohio Revised Code if it is determined by the Director of Finance that issuance of fully registered securities in that form will facilitate the sale and delivery of the Notes. The Notes shall not have coupons attached, shall be numbered as determined by the Director of Finance and shall express upon their faces the purpose, in summary terms, for which they are issued and that they are issued pursuant to this Ordinance. As used in this Section and this Ordinance:

“*Book entry form*” or “*book entry system*” means a form or system under which (a) the ownership of beneficial interests in the Notes and the principal of and interest on the Notes may be transferred only through a book entry, and (b) a single physical Note certificate in fully registered form is issued by the City and payable only to a Depository or its nominee as registered owner, with the certificate deposited with and “*immobilized*” in the custody of the Depository or its designated agent for that purpose. The book entry maintained by others than the City is the record that identifies the owners of beneficial interests in the Notes and that principal and interest.

“*Depository*” means any securities depository that is a clearing agency registered pursuant to the provisions of Section 17A of the Securities Exchange Act of 1934, operating and maintaining, with its Participants or otherwise, a book entry system to record ownership of beneficial interests in the Notes or the principal of and interest on the Notes, and to effect transfers of the Notes, in book entry form, and includes and means initially The Depository Trust Company (a limited purpose trust company).

“*Participant*” means any participant contracting with a Depository under a book entry system and includes securities brokers and dealers, banks and trust companies and clearing corporations.

The Notes may be issued to a Depository for use in a book entry system and, if and as long as a book entry system is utilized, (a) the Notes may be issued in the form of a single Note made payable to the Depository or its nominee and immobilized in the custody of the Depository or its agent for that purpose; (b) the beneficial owners in book entry form shall have no right to receive the Notes in the form of physical securities or certificates; (c) ownership of beneficial interests in book entry form shall be shown by book entry on the system maintained and operated by the Depository and its Participants, and transfers of the ownership of beneficial interests shall be made only by book entry by the Depository and its Participants; and (d) the Notes as such shall not be transferable or exchangeable, except for transfer to another Depository or to another nominee of a Depository, without further action by the City.

If any Depository determines not to continue to act as a Depository for the Notes for use in a book entry system, the Director of Finance may attempt to establish a securities depository/book entry relationship with another qualified Depository. If the Director of Finance does not or is unable to do so, the Director of Finance, after making provision for notification of the beneficial owners by the then Depository and any other arrangements deemed necessary, shall permit withdrawal of the Notes from the Depository, and shall cause the Notes in bearer or payable form to be signed by the officers

authorized to sign the Notes and delivered to the assigns of the Depository or its nominee, all at the cost and expense (including any costs of printing), if the event is not the result of City action or inaction, of those persons requesting such issuance.

The Director of Finance is also hereby authorized and directed, to the extent necessary or required, to enter into any agreements determined necessary in connection with the book entry system for the Notes, after determining that the signing thereof will not endanger the funds or securities of the City.

**Section 6.** Sale and Award of the Notes. The Notes shall be sold at not less than par plus accrued interest (if any) at private sale by the Director of Finance in accordance with law and the provisions of this Ordinance, the Certificate of Award and the Note Purchase Agreement. The Director of Finance shall sign the Certificate of Award referred to in Section 3 fixing the interest rate or rates which the Notes shall bear and evidencing that sale to the original purchaser, cause the Notes to be prepared, and have the Notes signed and delivered, together with a true transcript of proceedings with reference to the issuance of the Notes if requested by the original purchaser, to the original purchaser upon payment of the purchase price.

The Note Purchase Agreement by and between the City and the original purchaser and now on file with the Clerk of Council is approved, and the City Manager and the Director of Finance are authorized to sign and deliver, on behalf of the City, the Note Purchase Agreement with such changes that are not inconsistent with the provisions of this Ordinance, are not materially adverse to the interests of the City and are approved by the City Manager and the Director of Finance. Any such changes to the Note Purchase Agreement that are not materially adverse to the interests of the City and are approved by the City Manager and the Director of Finance shall be evidenced conclusively by the signing of the Note Purchase Agreement by the City Manager and the Director of Finance.

The City Manager, the Director of Finance, the Director of Law, the Clerk of Council and other City officials, as appropriate, and any person serving in an interim or acting capacity for any such official or as an assistant thereto, are each authorized and directed to sign any transcript certificates, financial statements and other documents and instruments and to take such actions as are necessary or appropriate to consummate the transactions contemplated by this Ordinance. Any actions heretofore taken by the City Manager, the Director of Finance, the Director of Law, the Clerk of Council or other City official, as appropriate, in doing any and all acts necessary in connection with the issuance and sale of the Notes are hereby ratified and confirmed. The Director of Finance is authorized, if it is determined to be in the best interest of the City, to combine the issue of Notes with one or more other note issues of the City into a consolidated note issue pursuant to Section 133.30(B) of the Ohio Revised Code.

**Section 7.** Application of Note Proceeds. The proceeds from the sale of the Notes received by the City (or withheld by the original purchaser or deposited with the Paying Agent, in each case on behalf of the City) shall be paid into the proper fund or funds, and those proceeds are appropriated and shall be used for the purpose for which the Notes are being issued. The Certificate of Award and the Note Purchase Agreement may authorize the original purchaser to (a) withhold certain proceeds from the sale of the Notes or (b) remit certain proceeds from the sale of the Notes to the Paying Agent, in each case to provide for the payment of certain financing costs on behalf of the City. If proceeds are remitted to the Paying Agent in accordance with this Section 7, the Paying Agent shall be authorized to create a fund in accordance with the Certificate of Award and/or Note Registrar Agreement for that purpose. Any portion of those proceeds received by the City (after payment of

those financing costs) representing premium or accrued interest shall be paid into the Bond Retirement Fund.

**Section 8.** Application and Pledge of Bond or Renewal Note Proceeds or Excess Funds. The par value to be received from the sale of the Bonds or of any renewal notes and any excess funds resulting from the issuance of the Notes shall, to the extent necessary, be used to pay the debt charges on the Notes at maturity and are pledged for that purpose.

**Section 9.** Provision for Tax Levy. During the year or years in which the Notes are outstanding, there shall be levied on all the taxable property in the City, in addition to all other taxes, the same tax that would have been levied if the Bonds had been issued without the prior issuance of the Notes. The tax shall be within the ten-mill limitation imposed by law, shall be and is ordered computed, certified, levied and extended upon the tax duplicate and collected by the same officers, in the same manner and at the same time that taxes for general purposes for each of those years are certified, levied, extended and collected, and shall be placed before and in preference to all other items and for the full amount thereof. The proceeds of the tax levy shall be placed in the Bond Retirement Fund, which is irrevocably pledged for the payment of the debt charges on the Notes or the Bonds when and as the same fall due.

In each year to the extent receipts from the municipal income tax are available for the payment of the debt charges on the Notes or the Bonds and are appropriated for that purpose, the amount of the tax shall be reduced by the amount of such receipts so available and appropriated in compliance with the following covenant. To the extent necessary, the debt charges on the Notes or the Bonds shall be paid from municipal income taxes lawfully available therefor under the Constitution and laws of the State of Ohio and the Charter of the City; and the City hereby covenants, subject and pursuant to such authority, including particularly Section 133.05(B)(7) of the Ohio Revised Code, to appropriate annually from such municipal income taxes such amount as is necessary to meet such annual debt charges.

Nothing in the preceding paragraph in any way diminishes the irrevocable pledge of the full faith and credit and general property taxing power of the City to the prompt payment of the debt charges on the Notes or the Bonds.

**Section 10.** Federal Tax Considerations. The City covenants that it will use, and will restrict the use and investment of, the proceeds of the Notes in such manner and to such extent as may be necessary so that (a) the Notes will not (i) constitute private activity bonds or arbitrage bonds under Sections 141 or 148 of the Internal Revenue Code of 1986, as amended (the "Code") or (ii) be treated other than as bonds the interest on which is excluded from gross income under Section 103 of the Code, and (b) the interest on the Notes will not be an item of tax preference under Section 57 of the Code.

The City further covenants that (a) it will take or cause to be taken such actions that may be required of it for the interest on the Notes to be and remain excluded from gross income for federal income tax purposes, (b) it will not take or authorize to be taken any actions that would adversely affect that exclusion, and (c) it, or persons acting for it, will, among other acts of compliance, (i) apply the proceeds of the Notes to the governmental purpose of the borrowing, (ii) restrict the yield on investment property, (iii) make timely and adequate payments to the federal government, (iv) maintain books and records and make calculations and reports and (v) refrain from certain uses of those

proceeds, and, as applicable, of property financed with such proceeds, all in such manner and to the extent necessary to assure such exclusion of that interest under the Code.

The Director of Finance, as fiscal officer, or any other officer of the City having responsibility for issuance of the Notes is hereby authorized (a) to make or effect any election, selection, designation, choice, consent, approval, or waiver on behalf of the City with respect to the Notes as the City is permitted to or required to make or give under the federal income tax laws, including, without limitation thereto, any of the elections available under Section 148 of the Code, for the purpose of assuring, enhancing or protecting favorable tax treatment or status of the Notes or interest thereon or assisting compliance with requirements for that purpose, reducing the burden or expense of such compliance, reducing the rebate amount or payments or penalties with respect to the Notes, or making payments of special amounts in lieu of making computations to determine, or paying, excess earnings as rebate, or obviating those amounts or payments with respect to the Notes, which action shall be in writing and signed by the officer, (b) to take any and all other actions, make or obtain calculations, make payments, and make or give reports, covenants and certifications of and on behalf of the City, as may be appropriate to assure the exclusion of interest from gross income and the intended tax status of the Notes, and (c) to give one or more appropriate certificates of the City, for inclusion in the transcript of proceedings for the Notes, setting forth the reasonable expectations of the City regarding the amount and use of all the proceeds of the Notes, the facts, circumstances and estimates on which they are based, and other facts and circumstances relevant to the tax treatment of the interest on and the tax status of the Notes. The Director of Finance or any other officer of the City having responsibility for issuance of the Notes is specifically authorized to designate the Notes as “qualified tax-exempt obligations” if such designation is applicable and desirable, and to make any related necessary representations and covenants.

Each covenant made in this Section with respect to the Notes is also made with respect to all issues any portion of the debt service on which is paid from proceeds of the Notes (and, if different, the original issue and any refunding issues in a series of refundings), to the extent such compliance is necessary to assure exclusion of interest on the Notes from gross income for federal income tax purposes, and the officers identified above are authorized to take actions with respect to those issues as they are authorized in this Section to take with respect to the Notes.

**Section 11.** Certification and Delivery of Ordinance. The Clerk of Council is directed to promptly deliver, or cause to be delivered, a certified copy of this Ordinance to the County Auditors of Franklin and Licking Counties, Ohio.

**Section 12.** Rating. The Director of Finance is authorized to request a rating for the Notes from Moody’s Ratings or S&P Global Ratings, or both, as the Director of Finance determines is in the best interest of the City. The expenditure of the amounts necessary to secure any such ratings as well as to pay the other financing costs (as defined in Section 133.01 of the Ohio Revised Code) in connection with the Notes is hereby authorized and approved and the amounts necessary to pay those costs are hereby appropriated from the proceeds of the Notes, if available, and otherwise from available moneys in the General Fund.

**Section 13.** Bond Counsel. The legal services of the law firm of Squire Patton Boggs (US) LLP, as bond counsel, are hereby retained. Those legal services shall be in the nature of legal advice and recommendations as to the documents and the proceedings in connection with the authorization, sale and issuance of the Notes and securities issued in renewal of the Notes and rendering at delivery

related legal opinions, all as set forth in the form of engagement letter from that firm which is now on file in the office of the Clerk of Council. In providing those legal services, as an independent contractor and in an attorney-client relationship, that firm shall not exercise any administrative discretion on behalf of this City in the formulation of public policy, expenditure of public funds, enforcement of laws, rules and regulations of the State of Ohio, any county or municipal corporation or of this City, or the execution of public trusts. For those legal services, that firm shall be paid just and reasonable compensation and shall be reimbursed for actual out-of-pocket expenses incurred in providing those legal services. To the extent they are not paid or reimbursed pursuant to the Note Purchase Agreement and/or the Note Registrar Agreement, the Director of Finance is authorized and directed to make appropriate certification as to the availability of funds for those fees and any reimbursement and to issue an appropriate order for their timely payment as written statements are submitted by that firm. The amounts necessary to pay those fees and any reimbursement are hereby appropriated from the proceeds of the Notes, if available, and otherwise from available moneys in the General Fund.

**Section 14.** Municipal Advisor. The services of Baker Tilly Municipal Advisors, LLC, as municipal advisor, are hereby retained. The municipal advisory services shall be in the nature of financial advice and recommendations in connection with the issuance and sale of the Notes. In rendering those municipal advisory services, as an independent contractor, that firm shall not exercise any administrative discretion on behalf of the City in the formulation of public policy, expenditure of public funds, enforcement of laws, rules and regulations of the State of Ohio, the City or any other political subdivision, or the execution of public trusts. That firm shall be paid just and reasonable compensation for those municipal advisory services and shall be reimbursed for the actual out-of-pocket expenses it incurs in rendering those municipal advisory services. To the extent they are not paid or reimbursed pursuant to the Note Purchase Agreement and/or the Note Registrar Agreement, the Director of Finance is authorized and directed to make appropriate certification as to the availability of funds for those fees and any reimbursement and to issue an appropriate order for their timely payment as written statements are submitted by that firm. The amounts necessary to pay those fees and any reimbursement are hereby appropriated from the proceeds of the Notes, if available, and otherwise from available moneys in the General Fund.

**Section 15.** Satisfaction of Conditions for Note Issuance. This City Council determines that all acts and conditions necessary to be done or performed by the City or to have been met precedent to and in the issuing of the Notes in order to make them legal, valid and binding general obligations of the City have been performed and have been met, or will at the time of delivery of the Notes have been performed and have been met, in regular and due form as required by law; that the full faith and credit and general property taxing power (as described in Section 9) of the City are pledged for the timely payment of the debt charges on the Notes; and that no statutory or constitutional limitation of indebtedness or taxation will have been exceeded in the issuance of the Notes.

**Section 16.** Compliance with Open Meeting Requirements. This City Council finds and determines that all formal actions of this City Council and any of its committees concerning and relating to the adoption of this Ordinance were taken in an open meeting of this City Council or any of its committees, and that all deliberations of this City Council and of any of its committees that resulted in those formal actions were in meetings open to the public, all in compliance with the law, including Section 121.22 of the Ohio Revised Code.

**Section 17. Captions and Headings.** The captions and headings in this Ordinance are solely for convenience of reference and in no way define, limit or describe the scope or intent of any Sections, subsections, paragraphs, subparagraphs or clause thereof. Reference to a Section means a section of this Ordinance unless otherwise indicated.

**Section 18. Declaration of Emergency.** For the reasons stated herein, this City Council hereby declares an emergency and waives the otherwise applicable 30-day referendum period.

**Section 19. Effective Date.** Pursuant to Article 6.07(A) of the New Albany Charter, this Ordinance shall take effect upon adoption.

**CERTIFIED AS ADOPTED** this \_\_\_\_\_ day of \_\_\_\_\_, 2026.

**Attest:**

\_\_\_\_\_  
Sloan T. Spalding  
Mayor

\_\_\_\_\_  
Jennifer H. Mason  
Clerk of Council

**Approved as to form:**

\_\_\_\_\_  
Benjamin S. Albrecht  
Law Director

**Legislation dates:**

Prepared:	03/26/2026
Revised:	04/03/2026
Introduced:	04/07/2026
Revised:	
Adopted:	
Effective:	



ORDINANCE O-09-2026

**AN ORDINANCE PROVIDING FOR THE ISSUANCE AND SALE OF BONDS IN THE MAXIMUM PRINCIPAL AMOUNT OF \$42,000,000 FOR THE PURPOSE OF PAYING THE COSTS OF PROVIDING FOR THE CONTINUING DEVELOPMENT OF THE VILLAGE CENTER BY CONSTRUCTING, ACQUIRING, RENOVATING AND IMPROVING DOWNTOWN INFRASTRUCTURE, INCLUDING PUBLIC ROADWAYS, STREETS, PARKING LOTS, PEDESTRIAN BRIDGES AND PARKS, AND RELATED CURBS AND GUTTERS, SIDEWALKS, WATER MAINS, SANITARY SEWERS AND STORM SEWERS, UTILITY CONDUITS, TRAFFIC AND PEDESTRIAN SIGNALS AND CONTROL DEVICES, LANDSCAPING, RESTORING ROSE RUN AND CONSTRUCTING AND INSTALLING PARK IMPROVEMENTS AND RELATED AMENITIES, AND OTHERWISE IMPROVING THE SITES THEREOF, AND ACQUIRING ANY RELATED INTERESTS IN REAL ESTATE, TOGETHER WITH ALL NECESSARY APPURTENANCES THERETO, AND DECLARING AN EMERGENCY**

**WHEREAS**, this City Council has requested that the Director of Finance, as fiscal officer of this City, certify the estimated life or period of usefulness of the Improvement described in Section 2 and the maximum maturity of the Bonds described in Section 2; and

**WHEREAS**, the Director of Finance has certified to this City Council that the estimated life or period of usefulness of the Improvement described in Section 2 is at least five (5) years and that the maximum maturity of the Bonds described in Section 2 is at least twenty (20) years; and

**WHEREAS**, this Ordinance constitutes an emergency measure necessary for the immediate preservation of the public peace, health, safety or welfare of the City, or for the further reason that this Ordinance is required to be immediately effective in order to permit the prompt issuance and sale of the Bonds, which is necessary to enable the City to enter into contracts to provide for the construction of the Improvement described in Section 2.

**NOW, THEREFORE, BE IT ORDAINED** by Council for the City of New Albany, Counties of Franklin and Licking, State of Ohio, that:

**Section 1. Definitions and Interpretation.** In addition to the words and terms elsewhere defined in this Ordinance, unless the context or use clearly indicates another or different meaning or intent:

*“Authorized Denominations”* means the denomination of \$5,000 or any integral multiple in excess thereof.

“*Bond Proceedings*” means, collectively, this Ordinance, the Certificate of Award, the Continuing Disclosure Agreement, the Registrar Agreement and such other proceedings of the City, including the Bonds, that provide collectively for, among other things, the rights of holders and beneficial owners of the Bonds, and to the extent it is determined necessary by the Director of Finance in the Certificate of Award, the Purchase Agreement.

“*Bond Register*” means all books and records necessary for the registration, exchange and transfer of Bonds as provided in Section 5.

“*Bond Registrar*” means a bank or trust company authorized to do business in the State and designated by the Director of Finance in the Certificate of Award pursuant to Section 4 as the initial authenticating agent, bond registrar, transfer agent and paying agent for the Bonds under the Registrar Agreement and until a successor Bond Registrar shall have become such pursuant to the provisions of the Registrar Agreement and, thereafter, “*Bond Registrar*” shall mean the successor Bond Registrar.

“*Bonds*” means, collectively, the Serial Bonds and the Term Bonds, each as is designated as such in the Certificate of Award.

“*Book entry form*” or “*book entry system*” means a form or system under which (a) the ownership of beneficial interests in the Bonds and the principal of and interest and any premium on the Bonds may be transferred only through a book entry, and (b) physical Bond certificates in fully registered form are issued by the City and payable only to a Depository or its nominee as registered owner, with the certificates deposited with and “immobilized” in the custody of the Depository or its designated agent for that purpose. The book entry maintained by others than the City is the record that identifies the owners of beneficial interests in the Bonds and that principal and interest.

“*Certificate of Award*” means the certificate authorized by Section 6, to be executed by the Director of Finance, setting forth and determining those terms or other matters pertaining to the Bonds and their issuance, sale and delivery as this Ordinance requires or authorizes to be set forth or determined therein.

“*City Manager*” means the City Manager of the City or any person serving in an interim or acting capacity with respect to that office.

“*Clerk of Council*” means the Clerk of Council of the City or any person serving in an interim or acting capacity with respect to that office.

“*Closing Date*” means the date of physical delivery of, and payment of the purchase price for, the Bonds.

“*Code*” means the Internal Revenue Code of 1986, as amended, the Regulations (whether temporary or final) under that Code or the statutory predecessor of that Code, and any amendments of, or successor provisions to, the foregoing and any official rulings, announcements, notices, procedures and judicial determinations regarding any of the foregoing, all as and to the extent applicable. Unless otherwise indicated, reference to a Section of the Code includes any applicable successor section or provision and such applicable Regulations, rulings, announcements, notices, procedures and determinations pertinent to that Section.

“*Continuing Disclosure Agreement*” means the Continuing Disclosure Agreement which shall constitute the continuing disclosure agreement made by the City for the benefit of the holders and beneficial owners of the Bonds in accordance with the Rule, as it may be modified from the form on file with the Clerk of Council and executed by the City Manager and the Director of Finance, all in accordance with Section 9(c).

“*Depository*” means any securities depository that is a clearing agency registered pursuant to the provisions of Section 17A of the Securities Exchange Act of 1934, operating and maintaining, with its Participants or otherwise, a book entry system to record ownership of beneficial interests in the Bonds or the principal of and interest and any premium on the Bonds, and to effect transfers of the Bonds, in book entry form, and includes and means initially The Depository Trust Company (a limited purpose trust company).

“*Director of Finance*” means the Director of Finance of the City or any person serving in an interim or acting capacity with respect to that office.

“*Director of Law*” means the Director of Law of the City or any person serving in an interim or acting capacity with respect to that office.

“*Financing Costs*” shall have the meaning given in Section 133.01 of the Ohio Revised Code.

“*Interest Payment Dates*” means, unless otherwise specified in the Certificate of Award, June 1 and December 1 of each year that the Bonds are outstanding, commencing on the date specified in the Certificate of Award.

“*Mandatory Redemption Date*” shall have the meaning set forth in Section 3(b).

“*Mandatory Sinking Fund Redemption Requirements*” shall have the meaning set forth in Section 3(e)(i).

“*Original Purchaser*” means the purchaser of the Bonds specified in the Certificate of Award.

“*Participant*” means any participant contracting with a Depository under a book entry system and includes securities brokers and dealers, banks and trust companies and clearing corporations.

“*Principal Payment Dates*” means, unless otherwise specified in the Certificate of Award, December 1 in each of the years from and including 2027 to and including 2046 as determined necessary by the Director of Finance in the Certificate of Award; *provided* that the first Principal Payment Date may be advanced up to one year and the last Principal Payment Date may be advanced by such number of years as determined necessary by the Director of Finance, and *provided further* that in no case shall the final Principal Payment Date exceed the maximum maturity limitation referred to in the preambles hereto, all of which determinations shall be made by the Director of Finance in the Certificate of Award in such manner as to be in the best interest of and financially advantageous to the City.

“*Purchase Agreement*” means the Bond Purchase Agreement, which to the extent it is determined necessary by the Director of Finance in the Certificate of Award, shall be between the City and the Original Purchaser, as it may be prepared, approved and executed by the City Manager and the Director of Finance, all in accordance with Section 6.

“*Registrar Agreement*” means the Bond Registrar Agreement between the City and the Bond Registrar, as it may be modified from the form on file with the Clerk of Council and executed by the City Manager and the Director of Finance, all in accordance with Section 4.

“*Regulations*” means Treasury Regulations issued pursuant to the Code or to the statutory predecessor of the Code.

“*Rule*” means Rule 15c2-12 prescribed by the SEC pursuant to the Securities Exchange Act of 1934.

“*SEC*” means the Securities and Exchange Commission.

“*Serial Bonds*” means those Bonds designated as such and maturing on the dates set forth in the Certificate of Award, bearing interest payable on each Interest Payment Date and not subject to mandatory sinking fund redemption.

“*State*” means the State of Ohio.

“*Term Bonds*” means those Bonds designated as such and maturing on the date or dates set forth in the Certificate of Award, bearing interest payable on each Interest Payment Date and subject to mandatory sinking fund redemption.

The captions and headings in this Ordinance are solely for convenience of reference and in no way define, limit or describe the scope or intent of any Sections, subsections, paragraphs, subparagraphs or clauses hereof. Reference to a Section means a section of this Ordinance unless otherwise indicated.

**Section 2.** Authorized Principal Amount and Purpose; Application of Proceeds. This City Council determines that it is necessary and in the best interest of the City to issue bonds of this City in the maximum principal amount of \$42,000,000 (the “*Bonds*”) for the purpose of paying the costs of providing for the continuing development of the Village Center by constructing, acquiring, renovating and improving downtown infrastructure, including public roadways, streets, parking lots, pedestrian bridges and parks, and related curbs and gutters, sidewalks, water mains, sanitary sewers and storm sewers, utility conduits, traffic and pedestrian signals and control devices, landscaping, restoring Rose Run and constructing and installing park improvements and related amenities, and otherwise improving the sites thereof, and acquiring any related interests in real estate, together with all necessary appurtenances thereto (the “*Improvement*”). The Bonds shall be issued pursuant to Chapter 133 of the Ohio Revised Code, the Charter of the City, this Ordinance and the Certificate of Award.

The principal amount of Bonds to be issued shall not exceed the maximum principal amount specified in this Section 2 and shall be an amount determined by the Director of Finance in the Certificate of Award to be the principal amount of Bonds that is required to be issued at this time for the purpose stated in this Section 2, taking into account the costs of the Improvement, the estimates of the Financing Costs and the interest rates on the Bonds.

The proceeds from the sale of the Bonds received by the City (or withheld by the Original Purchaser on behalf of the City) shall be paid into the proper fund or funds, and those proceeds are hereby appropriated and shall be used for the purpose for which the Bonds are being issued, including without limitation but only to the extent not paid by others, the payment of the costs of issuing and servicing the Bonds, printing and delivery of the Bonds, legal services including obtaining the approving legal opinion of bond counsel, fees and expenses of any municipal advisor, paying agent and rating agency,

any fees or premiums relating to municipal bond insurance or other security arrangements determined necessary by the Director of Finance, and all other Financing Costs and costs incurred incidental to those purposes. The Certificate of Award and the Purchase Agreement (if any) may authorize the Original Purchaser to withhold certain proceeds from the purchase price of the Bonds to provide for the payment of Financing Costs related to the Bonds on behalf of the City. Any portion of those proceeds received by the City representing premium (after payment of any Financing Costs identified in the Certificate of Award, and in the Purchase Agreement (if any) and/or the Registrar Agreement) or accrued interest shall be paid into the Bond Retirement Fund.

**Section 3. Denominations; Dating; Principal and Interest Payment and Redemption Provisions.**

The Bonds shall be issued in one lot and only as fully registered bonds, in Authorized Denominations, but in no case as to a particular maturity date exceeding the principal amount maturing on that date. The Bonds shall be dated as provided in the Certificate of Award, *provided* that their dated date shall not be more than sixty (60) days prior to the Closing Date.

(a) Interest Rates and Payment Dates. The Bonds shall bear interest at the rate or rates per year (computed on the basis of a 360-day year consisting of twelve 30-day months) as shall be determined by the Director of Finance, subject to subsection (c) of this Section 3, in the Certificate of Award. Interest on the Bonds shall be payable at such rate or rates on the Interest Payment Dates until the principal amount has been paid or provided for. The Bonds shall bear interest from the most recent date to which interest has been paid or provided for or, if no interest has been paid or provided for, from their date.

(b) Principal Payment Schedule. The Bonds shall mature or be payable pursuant to Mandatory Sinking Fund Redemption Requirements on the Principal Payment Dates in principal amounts as shall be determined by the Director of Finance, subject to subsection (c) of this Section 3, in the Certificate of Award, which determination shall be in the best interest of and financially advantageous to the City.

Consistent with the foregoing and in accordance with the Director of Finance's determination of the best interest of and financial advantages to the City, the Director of Finance shall specify in the Certificate of Award (i) the aggregate principal amount of Bonds to be issued as Serial Bonds, the Principal Payment Date or Dates on which those Bonds shall be stated to mature and the principal amount thereof that shall be stated to mature on each such Principal Payment Date and (ii) the aggregate principal amount of Bonds to be issued as Term Bonds, the Principal Payment Date or Dates on which those Bonds shall be stated to mature, the principal amount thereof that shall be stated to mature on each such Principal Payment Date, the Principal Payment Date or Dates on which Term Bonds shall be subject to mandatory sinking fund redemption (each a "*Mandatory Redemption Date*") and the principal amount thereof that shall be payable pursuant to Mandatory Sinking Fund Redemption Requirements on each Mandatory Redemption Date.

(c) Conditions for Establishment of Interest Rates and Principal Payment Dates and Amounts.

The rate or rates of interest per year to be borne by the Bonds, and the principal amount of Bonds maturing or payable pursuant to Mandatory Sinking Fund Redemption Requirements on each Principal Payment Date, shall be such that the total principal and interest payments on the Bonds in any fiscal year in which principal is payable is not more than three times the amount of those payments in any other fiscal year. The net interest cost for the Bonds determined by taking into account the respective principal amounts of the Bonds and terms to maturity or Mandatory Sinking Fund Redemption Requirements of those principal amounts of Bonds shall not exceed 6.00%.

(d) Payment of Debt Charges. The debt charges on the Bonds shall be payable in lawful money of the United States of America without deduction for the services of the Bond Registrar as paying agent. Principal of and any premium on the Bonds shall be payable when due upon presentation and surrender of the Bonds at the designated corporate trust office of the Bond Registrar. Interest on a Bond shall be paid on each Interest Payment Date by check or draft mailed to the person in whose name the Bond was registered, and to that person's address appearing, on the Bond Register at the close of business on the 15th day of the calendar month next preceding that Interest Payment Date. Notwithstanding the foregoing, if and so long as the Bonds are issued in a book entry system, principal of and interest and any premium on the Bonds shall be payable in the manner provided in any agreement entered into by the Director of Finance, in the name and on behalf of the City, in connection with the book entry system.

(e) Redemption Provisions. The Bonds shall be subject to redemption prior to stated maturity as follows:

(i) Mandatory Sinking Fund Redemption of Term Bonds. If any of the Bonds are issued as Term Bonds, the Term Bonds shall be subject to mandatory redemption in part by lot and be redeemed pursuant to mandatory sinking fund redemption requirements, at a redemption price of 100% of the principal amount redeemed, plus accrued interest to the redemption date, on the applicable Mandatory Redemption Dates and in the principal amounts payable on those Dates, for which provision is made in the Certificate of Award (such Dates and amounts being referred to as the "*Mandatory Sinking Fund Redemption Requirements*").

The aggregate of the moneys to be deposited with the Bond Registrar for payment of principal of and interest on any Term Bonds on each Mandatory Redemption Date shall include an amount sufficient to redeem on that Date the principal amount of Term Bonds payable on that Date pursuant to the Mandatory Sinking Fund Redemption Requirements (less the amount of any credit as hereinafter provided).

The City shall have the option to deliver to the Bond Registrar for cancellation Term Bonds in any aggregate principal amount and to receive a credit against the then current or any subsequent Mandatory Sinking Fund Redemption Requirement (and corresponding mandatory redemption obligation) of the City, as specified by the Director of Finance, for Term Bonds stated to mature on the same Principal Payment Date and bearing interest at the same rate as the Term Bonds so delivered. That option shall be exercised by the City on or before the 45<sup>th</sup> day preceding any Mandatory Redemption Date with respect to which the City wishes to obtain a credit, by furnishing the Bond Registrar a certificate, signed by the Director of Finance, setting forth the extent of the credit to be applied with respect to the then current or any subsequent Mandatory Sinking Fund Redemption Requirement for Term Bonds stated to mature on the same Principal Payment Date and bearing interest at the same rate as the Term Bonds so delivered. If the certificate is not timely furnished to the Bond Registrar, the current Mandatory Sinking Fund Redemption Requirement (and corresponding mandatory redemption obligation) shall not be reduced. A credit against the then current or any subsequent Mandatory Sinking Fund Redemption Requirement (and corresponding mandatory redemption obligation), as specified by the Director of Finance, also shall be received by the City for any Term Bonds which prior thereto have been redeemed (other than through the operation of the applicable Mandatory Sinking Fund Redemption Requirements) or purchased for cancellation and canceled by the Bond Registrar, to the extent not applied theretofore as a credit against any Mandatory Sinking Fund Redemption Requirement, for Term Bonds stated to mature on

the same Principal Payment Date and bearing interest at the same rate as the Term Bonds so redeemed or purchased and canceled.

Each Term Bond so delivered, or previously redeemed, or purchased and canceled, shall be credited by the Bond Registrar at 100% of the principal amount thereof against the then current or subsequent Mandatory Sinking Fund Redemption Requirements (and corresponding mandatory redemption obligations), as specified by the Director of Finance, for Term Bonds stated to mature on the same Principal Payment Date and bearing interest at the same rate as the Term Bonds so delivered, redeemed or purchased and canceled.

(ii) Optional Redemption. The Bonds of the maturities and interest rates specified in the Certificate of Award (if any are so specified) shall be subject to optional redemption by and at the sole option of the City, in whole or in part in integral multiples of \$5,000, on the dates and at the redemption prices (expressed as a percentage of the principal amount to be redeemed), plus accrued interest to the redemption date, to be determined by the Director of Finance in the Certificate of Award; *provided* that the redemption price for any optional redemption date shall not be greater than 103%.

If optional redemption of Term Bonds at a redemption price exceeding 100% of the principal amount to be redeemed is to take place as of any Mandatory Redemption Date applicable to those Term Bonds, the Term Bonds, or portions thereof, to be redeemed optionally shall be selected by lot prior to the selection by lot of the Term Bonds of the same maturity (and interest rate within a maturity if applicable) to be redeemed on the same date by operation of the Mandatory Sinking Fund Redemption Requirements. Bonds to be redeemed pursuant to this paragraph shall be redeemed only upon written notice from the Director of Finance to the Bond Registrar, given upon the direction of the City by passage of an ordinance or adoption of a resolution. That notice shall specify the redemption date and the principal amount of each maturity (and interest rate within a maturity if applicable) of Bonds to be redeemed, and shall be given at least 45 days prior to the redemption date or such shorter period as shall be acceptable to the Bond Registrar.

(iii) Partial Redemption. If fewer than all of the outstanding Bonds are called for optional redemption at one time and Bonds of more than one maturity (or interest rate within a maturity if applicable) are then outstanding, the Bonds that are called shall be Bonds of the maturity or maturities and interest rate or rates selected by the City. If fewer than all of the Bonds of a single maturity (or interest rate within a maturity if applicable) are to be redeemed, the selection of Bonds of that maturity (or interest rate within a maturity if applicable) to be redeemed, or portions thereof in amounts of \$5,000 or any integral multiple thereof, shall be made by the Bond Registrar by lot in a manner determined by the Bond Registrar. In the case of a partial redemption of Bonds by lot when Bonds of denominations greater than \$5,000 are then outstanding, each \$5,000 unit of principal thereof shall be treated as if it were a separate Bond of the denomination of \$5,000. If it is determined that one or more, but not all, of the \$5,000 units of principal amount represented by a Bond are to be called for redemption, then, upon notice of redemption of a \$5,000 unit or units, the registered owner of that Bond shall surrender the Bond to the Bond Registrar (A) for payment of the redemption price of the \$5,000 unit or units of principal amount called for redemption (including, without limitation, the interest accrued to the date fixed for redemption and any premium), and (B) for issuance, without charge to the registered owner, of a new Bond or Bonds of any Authorized Denomination or Denominations in an aggregate principal amount equal to the unmatured and unredeemed portion of, and bearing interest at the same rate and maturing on the same date as, the Bond surrendered.

(iv) Notice of Redemption. The notice of the call for redemption of Bonds shall identify (A) by designation, letters, numbers or other distinguishing marks, the Bonds or portions thereof to be redeemed, (B) the redemption price to be paid, (C) the date fixed for redemption, and (D) the place or places where the amounts due upon redemption are payable. The notice shall be given by the Bond Registrar on behalf of the City by mailing a copy of the redemption notice by first-class mail, postage prepaid, at least 30 days prior to the date fixed for redemption, to the registered owner of each Bond subject to redemption in whole or in part at the registered owner's address shown on the Bond Register maintained by the Bond Registrar at the close of business on the 15<sup>th</sup> day preceding that mailing. Failure to receive notice by mail or any defect in that notice regarding any Bond, however, shall not affect the validity of the proceedings for the redemption of any Bond.

(v) Payment of Redeemed Bonds. In the event that notice of redemption shall have been given by the Bond Registrar to the registered owners as provided above, there shall be deposited with the Bond Registrar on or prior to the redemption date, moneys that, in addition to any other moneys available therefor and held by the Bond Registrar, will be sufficient to redeem at the redemption price thereof, plus accrued interest to the redemption date, all of the redeemable Bonds for which notice of redemption has been given. Notice having been mailed in the manner provided in the preceding paragraph hereof, the Bonds and portions thereof called for redemption shall become due and payable on the redemption date, and, subject to the provisions of Sections 3(d) and 5, upon presentation and surrender thereof at the place or places specified in that notice, shall be paid at the redemption price, plus accrued interest to the redemption date. If moneys for the redemption of all of the Bonds and portions thereof to be redeemed, together with accrued interest thereon to the redemption date, are held by the Bond Registrar on the redemption date, so as to be available therefor on that date and, if notice of redemption has been deposited in the mail as aforesaid, then from and after the redemption date those Bonds and portions thereof called for redemption shall cease to bear interest and no longer shall be considered to be outstanding. If those moneys shall not be so available on the redemption date, or that notice shall not have been deposited in the mail as aforesaid, those Bonds and portions thereof shall continue to bear interest, until they are paid, at the same rate as they would have borne had they not been called for redemption. All moneys held by the Bond Registrar for the redemption of particular Bonds shall be held in trust for the account of the registered owners thereof and shall be paid to them, respectively, upon presentation and surrender of those Bonds; *provided* that any interest earned on the moneys so held by the Bond Registrar shall be for the account of and paid to the City to the extent not required for the payment of the Bonds called for redemption.

**Section 4.** Execution and Authentication of Bonds; Appointment of Bond Registrar. The Bonds shall be signed by the City Manager and the Director of Finance, in the name of the City and in their official capacities; *provided* that either or both of those signatures may be a facsimile. The Bonds shall be issued in the Authorized Denominations and numbers as requested by the Original Purchaser and approved by the Director of Finance, shall be numbered as determined by the Director of Finance in order to distinguish each Bond from any other Bond, and shall express upon their faces the purpose, in summary terms, for which they are issued and that they are issued pursuant to Chapter 133 of the Ohio Revised Code, the Charter of the City, this Ordinance and the Certificate of Award.

The Director of Finance is hereby authorized to designate in the Certificate of Award a bank or trust company authorized to do business in the State to act as the initial Bond Registrar. The City Manager and the Director of Finance shall sign and deliver, in the name and on behalf of the City, the Registrar Agreement between the City and the Bond Registrar, in substantially the form as is now on file with the Clerk of Council. The Registrar Agreement is approved, together with any changes or

amendments that are not inconsistent with this Ordinance and not substantially adverse to the City and that are approved by the City Manager and the Director of Finance on behalf of the City, all of which shall be conclusively evidenced by the signing of the Registrar Agreement or amendments thereto. The Director of Finance shall provide for the payment of the services rendered and for reimbursement of expenses incurred pursuant to the Registrar Agreement, except to the extent paid or reimbursed by the Original Purchaser and/or the Bond Registrar pursuant to the Certificate of Award, the Purchase Agreement (if any) and/or the Registrar Agreement, from the proceeds of the Bonds to the extent available and then from other money lawfully available and appropriated or to be appropriated for that purpose.

No Bond shall be valid or obligatory for any purpose or shall be entitled to any security or benefit under the Bond Proceedings unless and until the certificate of authentication printed on the Bond is signed by the Bond Registrar as authenticating agent. Authentication by the Bond Registrar shall be conclusive evidence that the Bond so authenticated has been duly issued, signed and delivered under, and is entitled to the security and benefit of, the Bond Proceedings. The certificate of authentication may be signed by any authorized officer or employee of the Bond Registrar or by any other person acting as an agent of the Bond Registrar and approved by the Director of Finance on behalf of the City. The same person need not sign the certificate of authentication on all of the Bonds.

**Section 5.     Registration; Transfer and Exchange; Book Entry System.**

(a)     Bond Register. So long as any of the Bonds remain outstanding, the City will cause the Bond Registrar to maintain and keep the Bond Register at its designated corporate trust office. Subject to the provisions of Sections 3(d) and 9(c), the person in whose name a Bond is registered on the Bond Register shall be regarded as the absolute owner of that Bond for all purposes of the Bond Proceedings. Payment of or on account of the debt charges on any Bond shall be made only to or upon the order of that person; neither the City nor the Bond Registrar shall be affected by any notice to the contrary, but the registration may be changed as provided in this Section 5. All such payments shall be valid and effectual to satisfy and discharge the City's liability upon the Bond, including interest, to the extent of the amount or amounts so paid.

(b)     Transfer and Exchange. Any Bond may be exchanged for Bonds of any Authorized Denomination upon presentation and surrender at the designated corporate trust office of the Bond Registrar, together with a request for exchange signed by the registered owner or by a person legally empowered to do so in a form satisfactory to the Bond Registrar. A Bond may be transferred only on the Bond Register upon presentation and surrender of the Bond at the designated corporate trust office of the Bond Registrar together with an assignment signed by the registered owner or by a person legally empowered to do so in a form satisfactory to the Bond Registrar. Upon exchange or transfer the Bond Registrar shall complete, authenticate and deliver a new Bond or Bonds of any Authorized Denomination or Denominations requested by the owner equal in the aggregate to the unmatured principal amount of the Bond surrendered and bearing interest at the same rate and maturing on the same date.

If manual signatures on behalf of the City are required, the Bond Registrar shall undertake the exchange or transfer of Bonds only after the new Bonds are signed by the authorized officers of the City. In all cases of Bonds exchanged or transferred, the City shall sign and the Bond Registrar shall authenticate and deliver Bonds in accordance with the provisions of the Bond Proceedings. The exchange or transfer shall be without charge to the owner, except that the City and Bond Registrar

may make a charge sufficient to reimburse them for any tax or other governmental charge required to be paid with respect to the exchange or transfer. The City or the Bond Registrar may require that those charges, if any, be paid before the procedure is begun for the exchange or transfer. All Bonds issued and authenticated upon any exchange or transfer shall be valid obligations of the City, evidencing the same debt, and entitled to the same security and benefit under the Bond Proceedings as the Bonds surrendered upon that exchange or transfer. Neither the City nor the Bond Registrar shall be required to make any exchange or transfer of (i) Bonds then subject to call for redemption between the 15<sup>th</sup> day preceding the mailing of notice of Bonds to be redeemed and the date of that mailing, or (ii) any Bond selected for redemption, in whole or in part.

(c) Book Entry System. Notwithstanding any other provisions of this Ordinance, if the Director of Finance determines in the Certificate of Award that it is in the best interest of and financially advantageous to the City, the Bonds may be issued in book entry form in accordance with the following provisions of this Section 5.

The Bonds may be issued to a Depository for use in a book entry system and, if and as long as a book entry system is utilized: (i) the Bonds may be issued in the form of a single, fully registered Bond representing each maturity, and, if applicable, each interest rate within a maturity, and registered in the name of the Depository or its nominee, as registered owner, and immobilized in the custody of the Depository or its designated agent for that purpose, which may be the Bond Registrar; (ii) the beneficial owners of Bonds in book entry form shall have no right to receive Bonds in the form of physical securities or certificates; (iii) ownership of beneficial interests in book entry form shall be shown by book entry on the system maintained and operated by the Depository and its Participants, and transfers of the ownership of beneficial interests shall be made only by book entry by the Depository and its Participants; and (iv) the Bonds as such shall not be transferable or exchangeable, except for transfer to another Depository or to another nominee of a Depository, without further action by the City.

If any Depository determines not to continue to act as a Depository for the Bonds for use in a book entry system, the Director of Finance may attempt to establish a securities depository/book entry relationship with another qualified Depository. If the Director of Finance does not or is unable to do so, the Director of Finance, after making provision for notification of the beneficial owners by the then Depository and any other arrangements deemed necessary, shall permit withdrawal of the Bonds from the Depository, and shall cause Bond certificates in registered form and Authorized Denominations to be authenticated by the Bond Registrar and delivered to the assigns of the Depository or its nominee, all at the cost and expense (including any costs of printing), if the event is not the result of City action or inaction, of those persons requesting such issuance.

The Director of Finance is hereby authorized and directed, to the extent necessary or required, to enter into any agreements, in the name and on behalf of the City, that the Director of Finance determines to be necessary in connection with a book entry system for the Bonds.

**Section 6.** Sale of the Bonds to the Original Purchaser. The Director of Finance is authorized to sell the Bonds at private sale to the Original Purchaser at a purchase price, not less than 97% of the aggregate principal amount thereof, as shall be determined by the Director of Finance in the Certificate of Award, plus accrued interest (if any) on the Bonds from their date to the Closing Date, and shall be awarded by the Director of Finance with and upon such other terms as are required or authorized by this Ordinance to be specified in the Certificate of Award, in accordance with law and the

provisions of this Ordinance and the Purchase Agreement (if any). The Director of Finance is authorized, if it is determined to be in the best interest of the City, to combine the issue of Bonds with one or more other bond issues of the City into a consolidated bond issue pursuant to Section 133.30(B) of the Ohio Revised Code in which case a single Certificate of Award may be utilized for the consolidated bond issue if appropriate and consistent with the terms of this Ordinance.

The Director of Finance shall sign and deliver the Certificate of Award and shall cause the Bonds to be prepared and signed and delivered, together with a true transcript of proceedings with reference to the issuance of the Bonds, to the Original Purchaser upon payment of the purchase price.

To the extent it is determined necessary by the Director of Finance in the Certificate of Award, the City Manager and the Director of Finance shall sign and deliver, in the name and on behalf of the City, the Purchase Agreement between the City and the Original Purchaser, in a form as is approved by the City Manager and the Director of Finance, providing for the sale to, and the purchase by, the Original Purchaser of the Bonds. The Purchase Agreement is approved, together with any changes or amendments that are not inconsistent with this Ordinance and not substantially adverse to the City and that are approved by the City Manager and the Director of Finance on behalf of the City, all of which shall be conclusively evidenced by the signing of the Purchase Agreement or amendments thereto.

The Mayor, the City Manager, the Director of Finance, the Director of Law, the Clerk of Council and other City officials, as appropriate, are each authorized and directed to sign any transcript certificates, financial statements and other documents and instruments and to take such actions as are necessary or appropriate to consummate the transactions contemplated by this Ordinance. Any actions heretofore taken by the Mayor, the City Manager, the Director of Finance, the Director of Law, the Clerk of Council or other City official, as appropriate, in doing any and all acts necessary in connection with the issuance and sale of the Bonds are hereby ratified and confirmed.

**Section 7.** Provision for Tax Levy. There shall be levied on all the taxable property in the City, in addition to all other taxes, a direct tax annually during the period the Bonds are outstanding in an amount sufficient to pay the debt charges on the Bonds when due, which tax shall not be less than the interest and sinking fund tax required by Section 11 of Article XII of the Ohio Constitution. The tax shall be within the ten-mill limitation imposed by law, shall be and is ordered computed, certified, levied and extended upon the tax duplicate and collected by the same officers, in the same manner and at the same time that taxes for general purposes for each of those years are certified, levied, extended and collected, and shall be placed before and in preference to all other items and for the full amount thereof. The proceeds of the tax levy shall be placed in the Bond Retirement Fund, which is irrevocably pledged for the payment of the debt charges on the Bonds when and as the same fall due.

In each year to the extent receipts from the municipal income tax are available for the payment of the debt charges on the Bonds and are appropriated for that purpose, the amount of the tax shall be reduced by the amount of such receipts so available and appropriated in compliance with the following covenant. To the extent necessary, the debt charges on the Bonds shall be paid from municipal income taxes lawfully available therefor under the Constitution and laws of the State, and the Charter of the City; and the City hereby covenants, subject and pursuant to such authority, including particularly Section 133.05(B)(7) of the Ohio Revised Code, to appropriate annually from such municipal income taxes such amount as is necessary to meet such annual debt charges.

Nothing in the preceding paragraph in any way diminishes the irrevocable pledge of the full faith and credit and general property taxing power of the City to the prompt payment of the debt charges on the Bonds.

**Section 8. Federal Tax Considerations.** The City covenants that it will use, and will restrict the use and investment of, the proceeds of the Bonds in such manner and to such extent as may be necessary so that (a) the Bonds will not (i) constitute private activity bonds or arbitrage bonds under Sections 141 or 148 of the Code or (ii) be treated other than as bonds the interest on which is excluded from gross income under Section 103 of the Code, and (b) the interest on the Bonds will not be an item of tax preference under Section 57 of the Code.

The City further covenants that (a) it will take or cause to be taken such actions that may be required of it for the interest on the Bonds to be and remain excluded from gross income for federal income tax purposes, (b) it will not take or authorize to be taken any actions that would adversely affect that exclusion, and (c) it, or persons acting for it, will, among other acts of compliance, (i) apply the proceeds of the Bonds to the governmental purpose of the borrowing, (ii) restrict the yield on investment property, (iii) make timely and adequate payments to the federal government, (iv) maintain books and records and make calculations and reports and (v) refrain from certain uses of those proceeds, and, as applicable, of property financed with such proceeds, all in such manner and to the extent necessary to assure such exclusion of that interest under the Code.

The Director of Finance or any other officer of the City having responsibility for issuance of the Bonds is hereby authorized (a) to make or effect any election, selection, designation, choice, consent, approval, or waiver on behalf of the City with respect to the Bonds as the City is permitted to or required to make or give under the federal income tax laws, including, without limitation thereto, any of the elections available under Section 148 of the Code, for the purpose of assuring, enhancing or protecting favorable tax treatment or status of the Bonds or interest thereon or assisting compliance with requirements for that purpose, reducing the burden or expense of such compliance, reducing the rebate amount or payments or penalties with respect to the Bonds, or making payments of special amounts in lieu of making computations to determine, or paying, excess earnings as rebate, or obviating those amounts or payments with respect to the Bonds, which action shall be in writing and signed by the officer, (b) to take any and all other actions, make or obtain calculations, make payments, and make or give reports, covenants and certifications of and on behalf of the City, as may be appropriate to assure the exclusion of interest from gross income and the intended tax status of the Bonds, and (c) to give one or more appropriate certificates of the City, for inclusion in the transcript of proceedings for the Bonds, setting forth the reasonable expectations of the City regarding the amount and use of all the proceeds of the Bonds, the facts, circumstances and estimates on which they are based, and other facts and circumstances relevant to the tax treatment of the interest on and the tax status of the Bonds. The Director of Finance or any other officer of the City having responsibility for issuance of the Bonds is specifically authorized to designate the Bonds as “qualified tax-exempt obligations” if such designation is applicable and desirable, and to make any related necessary representations and covenants.

**Section 9. Official Statement, Rating, Bond Insurance, Continuing Disclosure and Financing Costs.**

(a) Primary Offering Disclosure -- Official Statement. The City Manager and the Director of Finance are each authorized and directed, on behalf of the City and in their official capacities, to

(i) prepare or cause to be prepared, and make or authorize modifications, completions or changes of or supplements to, a disclosure document in the form of an official statement relating to the original issuance of the Bonds in substantially the form as is now on file with the Clerk of Council, (ii) determine, and to certify or otherwise represent, when the official statement is to be “deemed final” (except for permitted omissions) by the City as of its date or is a final official statement for purposes of paragraph (b) of the Rule, (iii) use and distribute, or authorize the use and distribution of those official statements and any supplements thereto in connection with the original issuance of the Bonds, and (iv) complete and sign those official statements and any supplements thereto as so approved, together with such certificates, statements or other documents in connection with the finality, accuracy and completeness of those official statements and any supplements, as they may deem necessary or appropriate.

(b) Application for Rating or Bond Insurance. If, in the judgment of the Director of Finance, the filing of an application for (i) a rating on the Bonds by one or more nationally recognized rating agencies, or (ii) a policy of insurance from a company or companies to better assure the payment of principal of and interest on the Bonds, is in the best interest of and financially advantageous to this City, the Director of Finance is authorized to prepare and submit those applications, to provide to each such agency or company such information as may be required for the purpose, and to provide further for the payment of the cost of obtaining each such rating or policy, except to the extent otherwise paid or reimbursed pursuant to the Certificate of Award, the Purchase Agreement (if any) and/or the Registrar Agreement, from the proceeds of the Bonds to the extent available and otherwise from any other funds lawfully available and that are appropriated or shall be appropriated for that purpose. The Director of Finance is hereby authorized, to the extent necessary or required, to enter into any agreements, in the name of and on behalf of the City, that the Director of Finance determines to be necessary in connection with the obtaining of that bond insurance.

(c) Agreement to Provide Continuing Disclosure. For the benefit of the holders and beneficial owners from time to time of the Bonds, the City agrees to provide or cause to be provided such financial information and operating data, audited financial statements and notices of the occurrence of certain events, in such manner as may be required for purposes of the Rule. The City Manager and the Director of Finance are each authorized and directed to complete, sign and deliver the Continuing Disclosure Agreement, in the name and on behalf of the City, in substantially the form as is now on file with the Clerk of Council. The Continuing Disclosure Agreement is approved, together with any changes or amendments that are not inconsistent with this Ordinance and not substantially adverse to the City and that are approved by the City Manager and the Director of Finance on behalf of the City, all of which shall be conclusively evidenced by the signing of the Continuing Disclosure Agreement or amendments thereto.

The Director of Finance is further authorized and directed to establish procedures in order to ensure compliance by the City with its Continuing Disclosure Agreement, including timely provision of information and notices as described above. Prior to making any filing required under the Rule, the Director of Finance shall consult with and obtain legal advice from, as appropriate, the Director of Law and bond or other qualified independent special counsel selected by the City. The Director of Finance, acting in the name and on behalf of the City, shall be entitled to rely upon any such legal advice in determining whether a filing should be made. The performance by the City of its Continuing Disclosure Agreement shall be subject to the annual appropriation of any funds that may be necessary to perform it.

(d) Financing Costs. The expenditure of the amounts necessary to pay any Financing Costs in connection with the Bonds, to the extent not paid or reimbursed by the Original Purchaser and/or the Bond Registrar pursuant to the Certificate of Award, the Purchase Agreement (if any) and/or the Registrar Agreement, is authorized and approved, and the Director of Finance is authorized to provide for the payment of any such amounts and costs from the proceeds of the Bonds to the extent available and otherwise from any other funds lawfully available that are appropriated or shall be appropriated for that purpose.

**Section 10.** Bond Counsel. The legal services of the law firm of Squire Patton Boggs (US) LLP, as bond counsel, are hereby retained. Those legal services shall be in the nature of legal advice and recommendations as to the documents and the proceedings in connection with the authorization, sale and issuance of the Bonds and rendering at delivery related legal opinions, all as set forth in the form of engagement letter from that firm which is now on file in the office of the Clerk of Council. In providing those legal services, as an independent contractor and in an attorney-client relationship, that firm shall not exercise any administrative discretion on behalf of this City in the formulation of public policy, expenditure of public funds, enforcement of laws, rules and regulations of the State, any county or municipal corporation or of this City, or the execution of public trusts. For those legal services, that firm shall be paid just and reasonable compensation and shall be reimbursed for actual out-of-pocket expenses incurred in providing those legal services. To the extent they are not paid or reimbursed pursuant to the Certificate of Award, the Purchase Agreement (if any) and/or the Registrar Agreement, the Director of Finance is authorized and directed to make appropriate certification as to the availability of funds for those fees and any reimbursement and to issue an appropriate order for their timely payment as written statements are submitted by that firm. The amounts necessary to pay those fees and any reimbursement are hereby appropriated from the proceeds of the Bonds, if available, and otherwise from available moneys in the General Fund.

**Section 11.** Municipal Advisor. The services of Baker Tilly Municipal Advisors, LLC, as municipal advisor, are hereby retained. The municipal advisory services shall be in the nature of financial advice and recommendations in connection with the issuance and sale of the Bonds. In rendering those municipal advisory services, as an independent contractor, that firm shall not exercise any administrative discretion on behalf of the City in the formulation of public policy, expenditure of public funds, enforcement of laws, rules and regulations of the State, the City or any other political subdivision, or the execution of public trusts. That firm shall be paid just and reasonable compensation for those municipal advisory services and shall be reimbursed for the actual out-of-pocket expenses it incurs in rendering those municipal advisory services. To the extent they are not paid or reimbursed pursuant to the Certificate of Award, the Purchase Agreement (if any) and/or the Registrar Agreement, the Director of Finance is authorized and directed to make appropriate certification as to the availability of funds for those fees and any reimbursement and to issue an appropriate order for their timely payment as written statements are submitted by that firm. The amounts necessary to pay those fees and any reimbursement are hereby appropriated from the proceeds of the Bonds, if available, and otherwise from available moneys in the General Fund.

**Section 12.** Certification and Delivery of Ordinance and Certificate of Award. The Clerk of Council is directed to promptly deliver or cause to be delivered a certified copy of this Ordinance and an executed copy of the Certificate of Award to the County Auditors of Franklin and Licking Counties, Ohio.

**Section 13.** Satisfaction of Conditions for Bond Issuance. This City Council determines that all acts and conditions necessary to be done or performed by the City or to have been met precedent to and in the issuing of the Bonds in order to make them legal, valid and binding general obligations of the City have been performed and have been met, or will at the time of delivery of the Bonds have been performed and have been met, in regular and due form as required by law; that the full faith and credit and general property taxing power (as described in Section 7) of the City are pledged for the timely payment of the debt charges on the Bonds; that no statutory or constitutional limitation of indebtedness or taxation will have been exceeded in the issuance of the Bonds; and that the Bonds are being authorized and issued pursuant to Chapter 133 of the Ohio Revised Code, the Charter of the City, this Ordinance, the Certificate of Award and other authorizing provisions of law.

**Section 14.** Compliance with Open Meeting Requirements. This City Council finds and determines that all formal actions of this City Council and any of its committees concerning and relating to the passage of this Ordinance were taken in an open meeting of this City Council or any of its committees, and that all deliberations of this City Council and of any of its committees that resulted in those formal actions were in meetings open to the public, all in compliance with the law, including Section 121.22 of the Ohio Revised Code.

**Section 15.** Declaration of Emergency. For the reasons stated herein, this City Council hereby declares an emergency and waives the otherwise applicable 30-day referendum period.

**Section 16.** Effective Date. Pursuant to Article 6.07(A) of the New Albany Charter, this Ordinance shall take effect upon adoption.

**CERTIFIED AS ADOPTED** this \_\_\_\_\_ day of \_\_\_\_\_, 2026.

**Attest:**

\_\_\_\_\_  
Sloan T. Spalding  
Mayor

\_\_\_\_\_  
Jennifer H. Mason  
Clerk of Council

**Approved as to form:**

\_\_\_\_\_  
Benjamin S. Albrecht  
Law Director

**Legislation dates:**

Prepared: 03/27/2026

Revised: 04/03/2026

Introduced: 04/07/2026

Revised:

Adopted:

Effective:



**ORDINANCE O-10-2026**

**AN ORDINANCE PROVIDING FOR THE ISSUANCE AND SALE OF BONDS IN THE MAXIMUM PRINCIPAL AMOUNT OF \$9,000,000 FOR THE PURPOSE OF PAYING THE COSTS OF IMPROVING THE MUNICIPAL SAFETY FACILITIES BY EXPANDING, IMPROVING, REMODELING, FURNISHING AND EQUIPPING THE POLICE HEADQUARTERS BUILDING, TOGETHER WITH ALL NECESSARY APPURTENANCES THERETO, AND DECLARING AN EMERGENCY**

**WHEREAS**, this City Council has requested that the Director of Finance, as fiscal officer of this City, certify the estimated life or period of usefulness of the Improvement described in Section 2 and the maximum maturity of the Bonds described in Section 2; and

**WHEREAS**, the Director of Finance has certified to this City Council that the estimated life or period of usefulness of the Improvement described in Section 2 is at least five (5) years and that the maximum maturity of the Bonds described in Section 2 is at least twenty (20) years; and

**WHEREAS**, this Ordinance constitutes an emergency measure necessary for the immediate preservation of the public peace, health, safety or welfare of the City, or for the further reason that this Ordinance is required to be immediately effective in order to permit the prompt issuance and sale of the Bonds, which is necessary to enable the City to enter into contracts to provide for the construction of the Improvement described in Section 2.

**NOW, THEREFORE, BE IT ORDAINED** by Council for the City of New Albany, Counties of Franklin and Licking, State of Ohio, that:

**Section 1. Definitions and Interpretation.** In addition to the words and terms elsewhere defined in this Ordinance, unless the context or use clearly indicates another or different meaning or intent:

*“Authorized Denominations”* means the denomination of \$5,000 or any integral multiple in excess thereof.

*“Bond Proceedings”* means, collectively, this Ordinance, the Certificate of Award, the Continuing Disclosure Agreement, the Registrar Agreement and such other proceedings of the City, including the Bonds, that provide collectively for, among other things, the rights of holders and beneficial owners of the Bonds, and to the extent it is determined necessary by the Director of Finance in the Certificate of Award, the Purchase Agreement.

*“Bond Register”* means all books and records necessary for the registration, exchange and transfer of Bonds as provided in Section 5.

“*Bond Registrar*” means a bank or trust company authorized to do business in the State and designated by the Director of Finance in the Certificate of Award pursuant to Section 4 as the initial authenticating agent, bond registrar, transfer agent and paying agent for the Bonds under the Registrar Agreement and until a successor Bond Registrar shall have become such pursuant to the provisions of the Registrar Agreement and, thereafter, “*Bond Registrar*” shall mean the successor Bond Registrar.

“*Bonds*” means, collectively, the Serial Bonds and the Term Bonds, each as is designated as such in the Certificate of Award.

“*Book entry form*” or “*book entry system*” means a form or system under which (a) the ownership of beneficial interests in the Bonds and the principal of and interest and any premium on the Bonds may be transferred only through a book entry, and (b) physical Bond certificates in fully registered form are issued by the City and payable only to a Depository or its nominee as registered owner, with the certificates deposited with and “immobilized” in the custody of the Depository or its designated agent for that purpose. The book entry maintained by others than the City is the record that identifies the owners of beneficial interests in the Bonds and that principal and interest.

“*Certificate of Award*” means the certificate authorized by Section 6, to be executed by the Director of Finance, setting forth and determining those terms or other matters pertaining to the Bonds and their issuance, sale and delivery as this Ordinance requires or authorizes to be set forth or determined therein.

“*City Manager*” means the City Manager of the City or any person serving in an interim or acting capacity with respect to that office.

“*Clerk of Council*” means the Clerk of Council of the City or any person serving in an interim or acting capacity with respect to that office.

“*Closing Date*” means the date of physical delivery of, and payment of the purchase price for, the Bonds.

“*Code*” means the Internal Revenue Code of 1986, as amended, the Regulations (whether temporary or final) under that Code or the statutory predecessor of that Code, and any amendments of, or successor provisions to, the foregoing and any official rulings, announcements, notices, procedures and judicial determinations regarding any of the foregoing, all as and to the extent applicable. Unless otherwise indicated, reference to a Section of the Code includes any applicable successor section or provision and such applicable Regulations, rulings, announcements, notices, procedures and determinations pertinent to that Section.

“*Continuing Disclosure Agreement*” means the Continuing Disclosure Agreement which shall constitute the continuing disclosure agreement made by the City for the benefit of the holders and beneficial owners of the Bonds in accordance with the Rule, as it may be modified from the form on file with the Clerk of Council and executed by the City Manager and the Director of Finance, all in accordance with Section 9(c).

“*Depository*” means any securities depository that is a clearing agency registered pursuant to the provisions of Section 17A of the Securities Exchange Act of 1934, operating and maintaining, with its Participants or otherwise, a book entry system to record ownership of beneficial interests in the Bonds or the principal of and interest and any premium on the Bonds, and to effect transfers of the Bonds,

in book entry form, and includes and means initially The Depository Trust Company (a limited purpose trust company).

“*Director of Finance*” means the Director of Finance of the City or any person serving in an interim or acting capacity with respect to that office.

“*Director of Law*” means the Director of Law of the City or any person serving in an interim or acting capacity with respect to that office.

“*Financing Costs*” shall have the meaning given in Section 133.01 of the Ohio Revised Code.

“*Interest Payment Dates*” means, unless otherwise specified in the Certificate of Award, June 1 and December 1 of each year that the Bonds are outstanding, commencing on the date specified in the Certificate of Award.

“*Mandatory Redemption Date*” shall have the meaning set forth in Section 3(b).

“*Mandatory Sinking Fund Redemption Requirements*” shall have the meaning set forth in Section 3(e)(i).

“*Original Purchaser*” means the purchaser of the Bonds specified in the Certificate of Award.

“*Participant*” means any participant contracting with a Depository under a book entry system and includes securities brokers and dealers, banks and trust companies and clearing corporations.

“*Principal Payment Dates*” means, unless otherwise specified in the Certificate of Award, December 1 in each of the years from and including 2027 to and including 2046 as determined necessary by the Director of Finance in the Certificate of Award; *provided* that the first Principal Payment Date may be advanced up to one year and the last Principal Payment Date may be advanced by such number of years as determined necessary by the Director of Finance, and *provided further* that in no case shall the final Principal Payment Date exceed the maximum maturity limitation referred to in the preambles hereto, all of which determinations shall be made by the Director of Finance in the Certificate of Award in such manner as to be in the best interest of and financially advantageous to the City.

“*Purchase Agreement*” means the Bond Purchase Agreement, which to the extent it is determined necessary by the Director of Finance in the Certificate of Award, shall be between the City and the Original Purchaser, as it may be prepared, approved and executed by the City Manager and the Director of Finance, all in accordance with Section 6.

“*Registrar Agreement*” means the Bond Registrar Agreement between the City and the Bond Registrar, as it may be modified from the form on file with the Clerk of Council and executed by the City Manager and the Director of Finance, all in accordance with Section 4.

“*Regulations*” means Treasury Regulations issued pursuant to the Code or to the statutory predecessor of the Code.

“*Rule*” means Rule 15c2-12 prescribed by the SEC pursuant to the Securities Exchange Act of 1934.

“*SEC*” means the Securities and Exchange Commission.

“*Serial Bonds*” means those Bonds designated as such and maturing on the dates set forth in the Certificate of Award, bearing interest payable on each Interest Payment Date and not subject to mandatory sinking fund redemption.

“*State*” means the State of Ohio.

“*Term Bonds*” means those Bonds designated as such and maturing on the date or dates set forth in the Certificate of Award, bearing interest payable on each Interest Payment Date and subject to mandatory sinking fund redemption.

The captions and headings in this Ordinance are solely for convenience of reference and in no way define, limit or describe the scope or intent of any Sections, subsections, paragraphs, subparagraphs or clauses hereof. Reference to a Section means a section of this Ordinance unless otherwise indicated.

**Section 2.** Authorized Principal Amount and Purpose; Application of Proceeds. This City Council determines that it is necessary and in the best interest of the City to issue bonds of this City in the maximum principal amount of \$9,000,000 (the “*Bonds*”) for the purpose of paying the costs of improving the municipal safety facilities by expanding, improving, remodeling, furnishing and equipping the police headquarters building, together with all necessary appurtenances thereto (the “*Improvement*”). The Bonds shall be issued pursuant to Chapter 133 of the Ohio Revised Code, the Charter of the City, this Ordinance and the Certificate of Award.

The principal amount of Bonds to be issued shall not exceed the maximum principal amount specified in this Section 2 and shall be an amount determined by the Director of Finance in the Certificate of Award to be the principal amount of Bonds that is required to be issued at this time for the purpose stated in this Section 2, taking into account the costs of the Improvement, the estimates of the Financing Costs and the interest rates on the Bonds.

The proceeds from the sale of the Bonds received by the City (or withheld by the Original Purchaser on behalf of the City) shall be paid into the proper fund or funds, and those proceeds are hereby appropriated and shall be used for the purpose for which the Bonds are being issued, including without limitation but only to the extent not paid by others, the payment of the costs of issuing and servicing the Bonds, printing and delivery of the Bonds, legal services including obtaining the approving legal opinion of bond counsel, fees and expenses of any municipal advisor, paying agent and rating agency, any fees or premiums relating to municipal bond insurance or other security arrangements determined necessary by the Director of Finance, and all other Financing Costs and costs incurred incidental to those purposes. The Certificate of Award and the Purchase Agreement (if any) may authorize the Original Purchaser to withhold certain proceeds from the purchase price of the Bonds to provide for the payment of Financing Costs related to the Bonds on behalf of the City. Any portion of those proceeds received by the City representing premium (after payment of any Financing Costs identified in the Certificate of Award, and in the Purchase Agreement (if any) and/or the Registrar Agreement) or accrued interest shall be paid into the Bond Retirement Fund.

**Section 3.** Denominations; Dating; Principal and Interest Payment and Redemption Provisions. The Bonds shall be issued in one lot and only as fully registered bonds, in Authorized Denominations, but in no case as to a particular maturity date exceeding the principal amount maturing on that date. The Bonds shall be dated as provided in the Certificate of Award, *provided* that their dated date shall not be more than sixty (60) days prior to the Closing Date.

(a) Interest Rates and Payment Dates. The Bonds shall bear interest at the rate or rates per year (computed on the basis of a 360-day year consisting of twelve 30-day months) as shall be determined by the Director of Finance, subject to subsection (c) of this Section 3, in the Certificate of Award. Interest on the Bonds shall be payable at such rate or rates on the Interest Payment Dates until the principal amount has been paid or provided for. The Bonds shall bear interest from the most recent date to which interest has been paid or provided for or, if no interest has been paid or provided for, from their date.

(b) Principal Payment Schedule. The Bonds shall mature or be payable pursuant to Mandatory Sinking Fund Redemption Requirements on the Principal Payment Dates in principal amounts as shall be determined by the Director of Finance, subject to subsection (c) of this Section 3, in the Certificate of Award, which determination shall be in the best interest of and financially advantageous to the City.

Consistent with the foregoing and in accordance with the Director of Finance's determination of the best interest of and financial advantages to the City, the Director of Finance shall specify in the Certificate of Award (i) the aggregate principal amount of Bonds to be issued as Serial Bonds, the Principal Payment Date or Dates on which those Bonds shall be stated to mature and the principal amount thereof that shall be stated to mature on each such Principal Payment Date and (ii) the aggregate principal amount of Bonds to be issued as Term Bonds, the Principal Payment Date or Dates on which those Bonds shall be stated to mature, the principal amount thereof that shall be stated to mature on each such Principal Payment Date, the Principal Payment Date or Dates on which Term Bonds shall be subject to mandatory sinking fund redemption (each a "*Mandatory Redemption Date*") and the principal amount thereof that shall be payable pursuant to Mandatory Sinking Fund Redemption Requirements on each Mandatory Redemption Date.

(c) Conditions for Establishment of Interest Rates and Principal Payment Dates and Amounts. The rate or rates of interest per year to be borne by the Bonds, and the principal amount of Bonds maturing or payable pursuant to Mandatory Sinking Fund Redemption Requirements on each Principal Payment Date, shall be such that the total principal and interest payments on the Bonds in any fiscal year in which principal is payable is not more than three times the amount of those payments in any other fiscal year. The net interest cost for the Bonds determined by taking into account the respective principal amounts of the Bonds and terms to maturity or Mandatory Sinking Fund Redemption Requirements of those principal amounts of Bonds shall not exceed 6.00%.

(d) Payment of Debt Charges. The debt charges on the Bonds shall be payable in lawful money of the United States of America without deduction for the services of the Bond Registrar as paying agent. Principal of and any premium on the Bonds shall be payable when due upon presentation and surrender of the Bonds at the designated corporate trust office of the Bond Registrar. Interest on a Bond shall be paid on each Interest Payment Date by check or draft mailed to the person in whose name the Bond was registered, and to that person's address appearing, on the Bond Register at the close of business on the 15th day of the calendar month next preceding that Interest Payment Date. Notwithstanding the foregoing, if and so long as the Bonds are issued in a book entry system, principal of and interest and any premium on the Bonds shall be payable in the manner provided in any agreement entered into by the Director of Finance, in the name and on behalf of the City, in connection with the book entry system.

(e) Redemption Provisions. The Bonds shall be subject to redemption prior to stated maturity as follows:

(i) Mandatory Sinking Fund Redemption of Term Bonds. If any of the Bonds are issued as Term Bonds, the Term Bonds shall be subject to mandatory redemption in part by lot and be redeemed pursuant to mandatory sinking fund redemption requirements, at a redemption price of 100% of the principal amount redeemed, plus accrued interest to the redemption date, on the applicable Mandatory Redemption Dates and in the principal amounts payable on those Dates, for which provision is made in the Certificate of Award (such Dates and amounts being referred to as the “*Mandatory Sinking Fund Redemption Requirements*”).

The aggregate of the moneys to be deposited with the Bond Registrar for payment of principal of and interest on any Term Bonds on each Mandatory Redemption Date shall include an amount sufficient to redeem on that Date the principal amount of Term Bonds payable on that Date pursuant to the Mandatory Sinking Fund Redemption Requirements (less the amount of any credit as hereinafter provided).

The City shall have the option to deliver to the Bond Registrar for cancellation Term Bonds in any aggregate principal amount and to receive a credit against the then current or any subsequent Mandatory Sinking Fund Redemption Requirement (and corresponding mandatory redemption obligation) of the City, as specified by the Director of Finance, for Term Bonds stated to mature on the same Principal Payment Date and bearing interest at the same rate as the Term Bonds so delivered. That option shall be exercised by the City on or before the 45<sup>th</sup> day preceding any Mandatory Redemption Date with respect to which the City wishes to obtain a credit, by furnishing the Bond Registrar a certificate, signed by the Director of Finance, setting forth the extent of the credit to be applied with respect to the then current or any subsequent Mandatory Sinking Fund Redemption Requirement for Term Bonds stated to mature on the same Principal Payment Date and bearing interest at the same rate as the Term Bonds so delivered. If the certificate is not timely furnished to the Bond Registrar, the current Mandatory Sinking Fund Redemption Requirement (and corresponding mandatory redemption obligation) shall not be reduced. A credit against the then current or any subsequent Mandatory Sinking Fund Redemption Requirement (and corresponding mandatory redemption obligation), as specified by the Director of Finance, also shall be received by the City for any Term Bonds which prior thereto have been redeemed (other than through the operation of the applicable Mandatory Sinking Fund Redemption Requirements) or purchased for cancellation and canceled by the Bond Registrar, to the extent not applied theretofore as a credit against any Mandatory Sinking Fund Redemption Requirement, for Term Bonds stated to mature on the same Principal Payment Date and bearing interest at the same rate as the Term Bonds so redeemed or purchased and canceled.

Each Term Bond so delivered, or previously redeemed, or purchased and canceled, shall be credited by the Bond Registrar at 100% of the principal amount thereof against the then current or subsequent Mandatory Sinking Fund Redemption Requirements (and corresponding mandatory redemption obligations), as specified by the Director of Finance, for Term Bonds stated to mature on the same Principal Payment Date and bearing interest at the same rate as the Term Bonds so delivered, redeemed or purchased and canceled.

(ii) Optional Redemption. The Bonds of the maturities and interest rates specified in the Certificate of Award (if any are so specified) shall be subject to optional redemption by and at the sole

option of the City, in whole or in part in integral multiples of \$5,000, on the dates and at the redemption prices (expressed as a percentage of the principal amount to be redeemed), plus accrued interest to the redemption date, to be determined by the Director of Finance in the Certificate of Award; *provided* that the redemption price for any optional redemption date shall not be greater than 103%.

If optional redemption of Term Bonds at a redemption price exceeding 100% of the principal amount to be redeemed is to take place as of any Mandatory Redemption Date applicable to those Term Bonds, the Term Bonds, or portions thereof, to be redeemed optionally shall be selected by lot prior to the selection by lot of the Term Bonds of the same maturity (and interest rate within a maturity if applicable) to be redeemed on the same date by operation of the Mandatory Sinking Fund Redemption Requirements. Bonds to be redeemed pursuant to this paragraph shall be redeemed only upon written notice from the Director of Finance to the Bond Registrar, given upon the direction of the City by passage of an ordinance or adoption of a resolution. That notice shall specify the redemption date and the principal amount of each maturity (and interest rate within a maturity if applicable) of Bonds to be redeemed, and shall be given at least 45 days prior to the redemption date or such shorter period as shall be acceptable to the Bond Registrar.

(iii) Partial Redemption. If fewer than all of the outstanding Bonds are called for optional redemption at one time and Bonds of more than one maturity (or interest rate within a maturity if applicable) are then outstanding, the Bonds that are called shall be Bonds of the maturity or maturities and interest rate or rates selected by the City. If fewer than all of the Bonds of a single maturity (or interest rate within a maturity if applicable) are to be redeemed, the selection of Bonds of that maturity (or interest rate within a maturity if applicable) to be redeemed, or portions thereof in amounts of \$5,000 or any integral multiple thereof, shall be made by the Bond Registrar by lot in a manner determined by the Bond Registrar. In the case of a partial redemption of Bonds by lot when Bonds of denominations greater than \$5,000 are then outstanding, each \$5,000 unit of principal thereof shall be treated as if it were a separate Bond of the denomination of \$5,000. If it is determined that one or more, but not all, of the \$5,000 units of principal amount represented by a Bond are to be called for redemption, then, upon notice of redemption of a \$5,000 unit or units, the registered owner of that Bond shall surrender the Bond to the Bond Registrar (A) for payment of the redemption price of the \$5,000 unit or units of principal amount called for redemption (including, without limitation, the interest accrued to the date fixed for redemption and any premium), and (B) for issuance, without charge to the registered owner, of a new Bond or Bonds of any Authorized Denomination or Denominations in an aggregate principal amount equal to the unmaturing and unredeemed portion of, and bearing interest at the same rate and maturing on the same date as, the Bond surrendered.

(iv) Notice of Redemption. The notice of the call for redemption of Bonds shall identify (A) by designation, letters, numbers or other distinguishing marks, the Bonds or portions thereof to be redeemed, (B) the redemption price to be paid, (C) the date fixed for redemption, and (D) the place or places where the amounts due upon redemption are payable. The notice shall be given by the Bond Registrar on behalf of the City by mailing a copy of the redemption notice by first-class mail, postage prepaid, at least 30 days prior to the date fixed for redemption, to the registered owner of each Bond subject to redemption in whole or in part at the registered owner's address shown on the Bond Register maintained by the Bond Registrar at the close of business on the 15<sup>th</sup> day preceding that mailing. Failure to receive notice by mail or any defect in that notice regarding any Bond, however, shall not affect the validity of the proceedings for the redemption of any Bond.

(v) Payment of Redeemed Bonds. In the event that notice of redemption shall have been given by the Bond Registrar to the registered owners as provided above, there shall be deposited with the Bond Registrar on or prior to the redemption date, moneys that, in addition to any other moneys available therefor and held by the Bond Registrar, will be sufficient to redeem at the redemption price thereof, plus accrued interest to the redemption date, all of the redeemable Bonds for which notice of redemption has been given. Notice having been mailed in the manner provided in the preceding paragraph hereof, the Bonds and portions thereof called for redemption shall become due and payable on the redemption date, and, subject to the provisions of Sections 3(d) and 5, upon presentation and surrender thereof at the place or places specified in that notice, shall be paid at the redemption price, plus accrued interest to the redemption date. If moneys for the redemption of all of the Bonds and portions thereof to be redeemed, together with accrued interest thereon to the redemption date, are held by the Bond Registrar on the redemption date, so as to be available therefor on that date and, if notice of redemption has been deposited in the mail as aforesaid, then from and after the redemption date those Bonds and portions thereof called for redemption shall cease to bear interest and no longer shall be considered to be outstanding. If those moneys shall not be so available on the redemption date, or that notice shall not have been deposited in the mail as aforesaid, those Bonds and portions thereof shall continue to bear interest, until they are paid, at the same rate as they would have borne had they not been called for redemption. All moneys held by the Bond Registrar for the redemption of particular Bonds shall be held in trust for the account of the registered owners thereof and shall be paid to them, respectively, upon presentation and surrender of those Bonds; *provided* that any interest earned on the moneys so held by the Bond Registrar shall be for the account of and paid to the City to the extent not required for the payment of the Bonds called for redemption.

**Section 4.** Execution and Authentication of Bonds; Appointment of Bond Registrar. The Bonds shall be signed by the City Manager and the Director of Finance, in the name of the City and in their official capacities; *provided* that either or both of those signatures may be a facsimile. The Bonds shall be issued in the Authorized Denominations and numbers as requested by the Original Purchaser and approved by the Director of Finance, shall be numbered as determined by the Director of Finance in order to distinguish each Bond from any other Bond, and shall express upon their faces the purpose, in summary terms, for which they are issued and that they are issued pursuant to Chapter 133 of the Ohio Revised Code, the Charter of the City, this Ordinance and the Certificate of Award.

The Director of Finance is hereby authorized to designate in the Certificate of Award a bank or trust company authorized to do business in the State to act as the initial Bond Registrar. The City Manager and the Director of Finance shall sign and deliver, in the name and on behalf of the City, the Registrar Agreement between the City and the Bond Registrar, in substantially the form as is now on file with the Clerk of Council. The Registrar Agreement is approved, together with any changes or amendments that are not inconsistent with this Ordinance and not substantially adverse to the City and that are approved by the City Manager and the Director of Finance on behalf of the City, all of which shall be conclusively evidenced by the signing of the Registrar Agreement or amendments thereto. The Director of Finance shall provide for the payment of the services rendered and for reimbursement of expenses incurred pursuant to the Registrar Agreement, except to the extent paid or reimbursed by the Original Purchaser and/or the Bond Registrar pursuant to the Certificate of Award, the Purchase Agreement (if any) and/or the Registrar Agreement, from the proceeds of the Bonds to the extent available and then from other money lawfully available and appropriated or to be appropriated for that purpose.

No Bond shall be valid or obligatory for any purpose or shall be entitled to any security or benefit under the Bond Proceedings unless and until the certificate of authentication printed on the Bond is signed by the Bond Registrar as authenticating agent. Authentication by the Bond Registrar shall be conclusive evidence that the Bond so authenticated has been duly issued, signed and delivered under, and is entitled to the security and benefit of, the Bond Proceedings. The certificate of authentication may be signed by any authorized officer or employee of the Bond Registrar or by any other person acting as an agent of the Bond Registrar and approved by the Director of Finance on behalf of the City. The same person need not sign the certificate of authentication on all of the Bonds.

**Section 5.     Registration; Transfer and Exchange; Book Entry System.**

(a)     Bond Register. So long as any of the Bonds remain outstanding, the City will cause the Bond Registrar to maintain and keep the Bond Register at its designated corporate trust office. Subject to the provisions of Sections 3(d) and 9(c), the person in whose name a Bond is registered on the Bond Register shall be regarded as the absolute owner of that Bond for all purposes of the Bond Proceedings. Payment of or on account of the debt charges on any Bond shall be made only to or upon the order of that person; neither the City nor the Bond Registrar shall be affected by any notice to the contrary, but the registration may be changed as provided in this Section 5. All such payments shall be valid and effectual to satisfy and discharge the City's liability upon the Bond, including interest, to the extent of the amount or amounts so paid.

(b)     Transfer and Exchange. Any Bond may be exchanged for Bonds of any Authorized Denomination upon presentation and surrender at the designated corporate trust office of the Bond Registrar, together with a request for exchange signed by the registered owner or by a person legally empowered to do so in a form satisfactory to the Bond Registrar. A Bond may be transferred only on the Bond Register upon presentation and surrender of the Bond at the designated corporate trust office of the Bond Registrar together with an assignment signed by the registered owner or by a person legally empowered to do so in a form satisfactory to the Bond Registrar. Upon exchange or transfer the Bond Registrar shall complete, authenticate and deliver a new Bond or Bonds of any Authorized Denomination or Denominations requested by the owner equal in the aggregate to the unmatured principal amount of the Bond surrendered and bearing interest at the same rate and maturing on the same date.

If manual signatures on behalf of the City are required, the Bond Registrar shall undertake the exchange or transfer of Bonds only after the new Bonds are signed by the authorized officers of the City. In all cases of Bonds exchanged or transferred, the City shall sign and the Bond Registrar shall authenticate and deliver Bonds in accordance with the provisions of the Bond Proceedings. The exchange or transfer shall be without charge to the owner, except that the City and Bond Registrar may make a charge sufficient to reimburse them for any tax or other governmental charge required to be paid with respect to the exchange or transfer. The City or the Bond Registrar may require that those charges, if any, be paid before the procedure is begun for the exchange or transfer. All Bonds issued and authenticated upon any exchange or transfer shall be valid obligations of the City, evidencing the same debt, and entitled to the same security and benefit under the Bond Proceedings as the Bonds surrendered upon that exchange or transfer. Neither the City nor the Bond Registrar shall be required to make any exchange or transfer of (i) Bonds then subject to call for redemption between the 15<sup>th</sup> day preceding the mailing of notice of Bonds to be redeemed and the date of that mailing, or (ii) any Bond selected for redemption, in whole or in part.

(c) Book Entry System. Notwithstanding any other provisions of this Ordinance, if the Director of Finance determines in the Certificate of Award that it is in the best interest of and financially advantageous to the City, the Bonds may be issued in book entry form in accordance with the following provisions of this Section 5.

The Bonds may be issued to a Depository for use in a book entry system and, if and as long as a book entry system is utilized: (i) the Bonds may be issued in the form of a single, fully registered Bond representing each maturity, and, if applicable, each interest rate within a maturity, and registered in the name of the Depository or its nominee, as registered owner, and immobilized in the custody of the Depository or its designated agent for that purpose, which may be the Bond Registrar; (ii) the beneficial owners of Bonds in book entry form shall have no right to receive Bonds in the form of physical securities or certificates; (iii) ownership of beneficial interests in book entry form shall be shown by book entry on the system maintained and operated by the Depository and its Participants, and transfers of the ownership of beneficial interests shall be made only by book entry by the Depository and its Participants; and (iv) the Bonds as such shall not be transferable or exchangeable, except for transfer to another Depository or to another nominee of a Depository, without further action by the City.

If any Depository determines not to continue to act as a Depository for the Bonds for use in a book entry system, the Director of Finance may attempt to establish a securities depository/book entry relationship with another qualified Depository. If the Director of Finance does not or is unable to do so, the Director of Finance, after making provision for notification of the beneficial owners by the then Depository and any other arrangements deemed necessary, shall permit withdrawal of the Bonds from the Depository, and shall cause Bond certificates in registered form and Authorized Denominations to be authenticated by the Bond Registrar and delivered to the assigns of the Depository or its nominee, all at the cost and expense (including any costs of printing), if the event is not the result of City action or inaction, of those persons requesting such issuance.

The Director of Finance is hereby authorized and directed, to the extent necessary or required, to enter into any agreements, in the name and on behalf of the City, that the Director of Finance determines to be necessary in connection with a book entry system for the Bonds.

**Section 6.** Sale of the Bonds to the Original Purchaser. The Director of Finance is authorized to sell the Bonds at private sale to the Original Purchaser at a purchase price, not less than 97% of the aggregate principal amount thereof, as shall be determined by the Director of Finance in the Certificate of Award, plus accrued interest (if any) on the Bonds from their date to the Closing Date, and shall be awarded by the Director of Finance with and upon such other terms as are required or authorized by this Ordinance to be specified in the Certificate of Award, in accordance with law and the provisions of this Ordinance and the Purchase Agreement (if any). The Director of Finance is authorized, if it is determined to be in the best interest of the City, to combine the issue of Bonds with one or more other bond issues of the City into a consolidated bond issue pursuant to Section 133.30(B) of the Ohio Revised Code in which case a single Certificate of Award may be utilized for the consolidated bond issue if appropriate and consistent with the terms of this Ordinance.

The Director of Finance shall sign and deliver the Certificate of Award and shall cause the Bonds to be prepared and signed and delivered, together with a true transcript of proceedings with reference to the issuance of the Bonds, to the Original Purchaser upon payment of the purchase price.

To the extent it is determined necessary by the Director of Finance in the Certificate of Award, the City Manager and the Director of Finance shall sign and deliver, in the name and on behalf of the City, the Purchase Agreement between the City and the Original Purchaser, in a form as is approved by the City Manager and the Director of Finance, providing for the sale to, and the purchase by, the Original Purchaser of the Bonds. The Purchase Agreement is approved, together with any changes or amendments that are not inconsistent with this Ordinance and not substantially adverse to the City and that are approved by the City Manager and the Director of Finance on behalf of the City, all of which shall be conclusively evidenced by the signing of the Purchase Agreement or amendments thereto.

The Mayor, the City Manager, the Director of Finance, the Director of Law, the Clerk of Council and other City officials, as appropriate, are each authorized and directed to sign any transcript certificates, financial statements and other documents and instruments and to take such actions as are necessary or appropriate to consummate the transactions contemplated by this Ordinance. Any actions heretofore taken by the Mayor, the City Manager, the Director of Finance, the Director of Law, the Clerk of Council or other City official, as appropriate, in doing any and all acts necessary in connection with the issuance and sale of the Bonds are hereby ratified and confirmed.

**Section 7.** Provision for Tax Levy. There shall be levied on all the taxable property in the City, in addition to all other taxes, a direct tax annually during the period the Bonds are outstanding in an amount sufficient to pay the debt charges on the Bonds when due, which tax shall not be less than the interest and sinking fund tax required by Section 11 of Article XII of the Ohio Constitution. The tax shall be within the ten-mill limitation imposed by law, shall be and is ordered computed, certified, levied and extended upon the tax duplicate and collected by the same officers, in the same manner and at the same time that taxes for general purposes for each of those years are certified, levied, extended and collected, and shall be placed before and in preference to all other items and for the full amount thereof. The proceeds of the tax levy shall be placed in the Bond Retirement Fund, which is irrevocably pledged for the payment of the debt charges on the Bonds when and as the same fall due.

In each year to the extent receipts from the municipal income tax are available for the payment of the debt charges on the Bonds and are appropriated for that purpose, the amount of the tax shall be reduced by the amount of such receipts so available and appropriated in compliance with the following covenant. To the extent necessary, the debt charges on the Bonds shall be paid from municipal income taxes lawfully available therefor under the Constitution and laws of the State, and the Charter of the City; and the City hereby covenants, subject and pursuant to such authority, including particularly Section 133.05(B)(7) of the Ohio Revised Code, to appropriate annually from such municipal income taxes such amount as is necessary to meet such annual debt charges.

Nothing in the preceding paragraph in any way diminishes the irrevocable pledge of the full faith and credit and general property taxing power of the City to the prompt payment of the debt charges on the Bonds.

**Section 8.** Federal Tax Considerations. The City covenants that it will use, and will restrict the use and investment of, the proceeds of the Bonds in such manner and to such extent as may be necessary so that (a) the Bonds will not (i) constitute private activity bonds or arbitrage bonds under Sections 141 or 148 of the Code or (ii) be treated other than as bonds the interest on which is excluded from gross income under Section 103 of the Code, and (b) the interest on the Bonds will not be an item of tax preference under Section 57 of the Code.

The City further covenants that (a) it will take or cause to be taken such actions that may be required of it for the interest on the Bonds to be and remain excluded from gross income for federal income tax purposes, (b) it will not take or authorize to be taken any actions that would adversely affect that exclusion, and (c) it, or persons acting for it, will, among other acts of compliance, (i) apply the proceeds of the Bonds to the governmental purpose of the borrowing, (ii) restrict the yield on investment property, (iii) make timely and adequate payments to the federal government, (iv) maintain books and records and make calculations and reports and (v) refrain from certain uses of those proceeds, and, as applicable, of property financed with such proceeds, all in such manner and to the extent necessary to assure such exclusion of that interest under the Code.

The Director of Finance or any other officer of the City having responsibility for issuance of the Bonds is hereby authorized (a) to make or effect any election, selection, designation, choice, consent, approval, or waiver on behalf of the City with respect to the Bonds as the City is permitted to or required to make or give under the federal income tax laws, including, without limitation thereto, any of the elections available under Section 148 of the Code, for the purpose of assuring, enhancing or protecting favorable tax treatment or status of the Bonds or interest thereon or assisting compliance with requirements for that purpose, reducing the burden or expense of such compliance, reducing the rebate amount or payments or penalties with respect to the Bonds, or making payments of special amounts in lieu of making computations to determine, or paying, excess earnings as rebate, or obviating those amounts or payments with respect to the Bonds, which action shall be in writing and signed by the officer, (b) to take any and all other actions, make or obtain calculations, make payments, and make or give reports, covenants and certifications of and on behalf of the City, as may be appropriate to assure the exclusion of interest from gross income and the intended tax status of the Bonds, and (c) to give one or more appropriate certificates of the City, for inclusion in the transcript of proceedings for the Bonds, setting forth the reasonable expectations of the City regarding the amount and use of all the proceeds of the Bonds, the facts, circumstances and estimates on which they are based, and other facts and circumstances relevant to the tax treatment of the interest on and the tax status of the Bonds. The Director of Finance or any other officer of the City having responsibility for issuance of the Bonds is specifically authorized to designate the Bonds as “qualified tax-exempt obligations” if such designation is applicable and desirable, and to make any related necessary representations and covenants.

**Section 9. Official Statement, Rating, Bond Insurance, Continuing Disclosure and Financing Costs.**

(a) Primary Offering Disclosure -- Official Statement. The City Manager and the Director of Finance are each authorized and directed, on behalf of the City and in their official capacities, to (i) prepare or cause to be prepared, and make or authorize modifications, completions or changes of or supplements to, a disclosure document in the form of an official statement relating to the original issuance of the Bonds in substantially the form as is now on file with the Clerk of Council, (ii) determine, and to certify or otherwise represent, when the official statement is to be “deemed final” (except for permitted omissions) by the City as of its date or is a final official statement for purposes of paragraph (b) of the Rule, (iii) use and distribute, or authorize the use and distribution of those official statements and any supplements thereto in connection with the original issuance of the Bonds, and (iv) complete and sign those official statements and any supplements thereto as so approved, together with such certificates, statements or other documents in connection with the finality, accuracy and completeness of those official statements and any supplements, as they may deem necessary or appropriate.

(b) Application for Rating or Bond Insurance. If, in the judgment of the Director of Finance, the filing of an application for (i) a rating on the Bonds by one or more nationally recognized rating agencies, or (ii) a policy of insurance from a company or companies to better assure the payment of principal of and interest on the Bonds, is in the best interest of and financially advantageous to this City, the Director of Finance is authorized to prepare and submit those applications, to provide to each such agency or company such information as may be required for the purpose, and to provide further for the payment of the cost of obtaining each such rating or policy, except to the extent otherwise paid or reimbursed pursuant to the Certificate of Award, the Purchase Agreement (if any) and/or the Registrar Agreement, from the proceeds of the Bonds to the extent available and otherwise from any other funds lawfully available and that are appropriated or shall be appropriated for that purpose. The Director of Finance is hereby authorized, to the extent necessary or required, to enter into any agreements, in the name of and on behalf of the City, that the Director of Finance determines to be necessary in connection with the obtaining of that bond insurance.

(c) Agreement to Provide Continuing Disclosure. For the benefit of the holders and beneficial owners from time to time of the Bonds, the City agrees to provide or cause to be provided such financial information and operating data, audited financial statements and notices of the occurrence of certain events, in such manner as may be required for purposes of the Rule. The City Manager and the Director of Finance are each authorized and directed to complete, sign and deliver the Continuing Disclosure Agreement, in the name and on behalf of the City, in substantially the form as is now on file with the Clerk of Council. The Continuing Disclosure Agreement is approved, together with any changes or amendments that are not inconsistent with this Ordinance and not substantially adverse to the City and that are approved by the City Manager and the Director of Finance on behalf of the City, all of which shall be conclusively evidenced by the signing of the Continuing Disclosure Agreement or amendments thereto.

The Director of Finance is further authorized and directed to establish procedures in order to ensure compliance by the City with its Continuing Disclosure Agreement, including timely provision of information and notices as described above. Prior to making any filing required under the Rule, the Director of Finance shall consult with and obtain legal advice from, as appropriate, the Director of Law and bond or other qualified independent special counsel selected by the City. The Director of Finance, acting in the name and on behalf of the City, shall be entitled to rely upon any such legal advice in determining whether a filing should be made. The performance by the City of its Continuing Disclosure Agreement shall be subject to the annual appropriation of any funds that may be necessary to perform it.

(d) Financing Costs. The expenditure of the amounts necessary to pay any Financing Costs in connection with the Bonds, to the extent not paid or reimbursed by the Original Purchaser and/or the Bond Registrar pursuant to the Certificate of Award, the Purchase Agreement (if any) and/or the Registrar Agreement, is authorized and approved, and the Director of Finance is authorized to provide for the payment of any such amounts and costs from the proceeds of the Bonds to the extent available and otherwise from any other funds lawfully available that are appropriated or shall be appropriated for that purpose.

**Section 10.** Bond Counsel. The legal services of the law firm of Squire Patton Boggs (US) LLP, as bond counsel, are hereby retained. Those legal services shall be in the nature of legal advice and recommendations as to the documents and the proceedings in connection with the authorization, sale and issuance of the Bonds and rendering at delivery related legal opinions, all as set forth in the form

of engagement letter from that firm which is now on file in the office of the Clerk of Council. In providing those legal services, as an independent contractor and in an attorney-client relationship, that firm shall not exercise any administrative discretion on behalf of this City in the formulation of public policy, expenditure of public funds, enforcement of laws, rules and regulations of the State, any county or municipal corporation or of this City, or the execution of public trusts. For those legal services, that firm shall be paid just and reasonable compensation and shall be reimbursed for actual out-of-pocket expenses incurred in providing those legal services. To the extent they are not paid or reimbursed pursuant to the Certificate of Award, the Purchase Agreement (if any) and/or the Registrar Agreement, the Director of Finance is authorized and directed to make appropriate certification as to the availability of funds for those fees and any reimbursement and to issue an appropriate order for their timely payment as written statements are submitted by that firm. The amounts necessary to pay those fees and any reimbursement are hereby appropriated from the proceeds of the Bonds, if available, and otherwise from available moneys in the General Fund.

**Section 11.** Municipal Advisor. The services of Baker Tilly Municipal Advisors, LLC, as municipal advisor, are hereby retained. The municipal advisory services shall be in the nature of financial advice and recommendations in connection with the issuance and sale of the Bonds. In rendering those municipal advisory services, as an independent contractor, that firm shall not exercise any administrative discretion on behalf of the City in the formulation of public policy, expenditure of public funds, enforcement of laws, rules and regulations of the State, the City or any other political subdivision, or the execution of public trusts. That firm shall be paid just and reasonable compensation for those municipal advisory services and shall be reimbursed for the actual out-of-pocket expenses it incurs in rendering those municipal advisory services. To the extent they are not paid or reimbursed pursuant to the Certificate of Award, the Purchase Agreement (if any) and/or the Registrar Agreement, the Director of Finance is authorized and directed to make appropriate certification as to the availability of funds for those fees and any reimbursement and to issue an appropriate order for their timely payment as written statements are submitted by that firm. The amounts necessary to pay those fees and any reimbursement are hereby appropriated from the proceeds of the Bonds, if available, and otherwise from available moneys in the General Fund.

**Section 12.** Certification and Delivery of Ordinance and Certificate of Award. The Clerk of Council is directed to promptly deliver or cause to be delivered a certified copy of this Ordinance and an executed copy of the Certificate of Award to the County Auditors of Franklin and Licking Counties, Ohio.

**Section 13.** Satisfaction of Conditions for Bond Issuance. This City Council determines that all acts and conditions necessary to be done or performed by the City or to have been met precedent to and in the issuing of the Bonds in order to make them legal, valid and binding general obligations of the City have been performed and have been met, or will at the time of delivery of the Bonds have been performed and have been met, in regular and due form as required by law; that the full faith and credit and general property taxing power (as described in Section 7) of the City are pledged for the timely payment of the debt charges on the Bonds; that no statutory or constitutional limitation of indebtedness or taxation will have been exceeded in the issuance of the Bonds; and that the Bonds are being authorized and issued pursuant to Chapter 133 of the Ohio Revised Code, the Charter of the City, this Ordinance, the Certificate of Award and other authorizing provisions of law.

**Section 14.** Compliance with Open Meeting Requirements. This City Council finds and determines that all formal actions of this City Council and any of its committees concerning and

relating to the passage of this Ordinance were taken in an open meeting of this City Council or any of its committees, and that all deliberations of this City Council and of any of its committees that resulted in those formal actions were in meetings open to the public, all in compliance with the law, including Section 121.22 of the Ohio Revised Code.

**Section 15.** Declaration of Emergency. For the reasons stated herein, this City Council hereby declares an emergency and waives the otherwise applicable 30-day referendum period.

**Section 16.** Effective Date. Pursuant to Article 6.07(A) of the New Albany Charter, this Ordinance shall take effect upon adoption.

**CERTIFIED AS ADOPTED** this \_\_\_\_\_ day of \_\_\_\_\_, 2026.

**Attest:**

\_\_\_\_\_  
Sloan T. Spalding  
Mayor

\_\_\_\_\_  
Jennifer H. Mason  
Clerk of Council

**Approved as to form:**

\_\_\_\_\_  
Benjamin S. Albrecht  
Law Director

**Legislation dates:**

Prepared:	03/27/2026
Revised:	04/03/2026
Introduced:	04/07/2026
Revised:	
Adopted:	
Effective:	



**ORDINANCE O-11-2026**

**AN ORDINANCE DESIGNATING THE CITY OF NEW ALBANY AS THE ENTITY PERFORMING CONVENTION AND VISITORS BUREAU FUNCTIONS AND AUTHORIZING THE USE OF TRANSIENT OCCUPANCY TAX REVENUES FOR SUCH PURPOSES**

**WHEREAS**, the City of New Albany (hereinafter, the “City”) previously adopted Ordinance O-07-2010 enacting Chapter 184 and levying a transient occupancy tax; and

**WHEREAS**, Chapter 184 provides that one-half (50%) of the revenues from the additional three percent (3%) tax shall be used for tourism-related purposes; and

**WHEREAS**, the City previously contracted with the New Albany Chamber of Commerce (hereinafter, the “Chamber”) for these services; and

**WHEREAS**, such agreement was terminated effective February 28, 2026, and the City has assumed responsibility for such functions in order to provide continued and enhanced tourism promotion and strategic community programming; and

**WHEREAS**, the City desires to designate an internal department to perform Convention and Visitors Bureau functions and to administer tourism-related programs and expenditures in a manner consistent with Ohio Revised Code Section 5739.08; and

**WHEREAS**, the City has determined that its Strategic Initiatives Department, including its Community Investment and Programming division, is best suited to carry out such tourism promotion, event coordination, and visitor-related activities.

**NOW, THEREFORE, BE IT ORDAINED** by the Council of the City of New Albany, Counties of Franklin and Licking, State of Ohio that:

**Section 1.** The City of New Albany hereby designates itself as the entity performing Convention and Visitors Bureau functions effective March 1, 2023. Following termination of the Chamber agreement, the City shall administer all funds directly.

**Section 2.** The City’s Strategic Initiatives Department is designated to carry out these functions. The City’s Strategic Initiatives Department shall ensure compliance and documentation.

**Section 3.** The Hotel Tax Fund shall continue to receive fifty percent (50%) of revenues from the additional three percent (3%) tax. Funds shall be used for tourism promotion, marketing, events, and visitor-related activities.

**Section 4.** This ordinance does not modify tax rates or allocations.

**Section 5.** It is hereby found and determined that all formal actions of this council concerning and relating to the adoption of this legislation were adopted in an open meeting of the council, and that all deliberations of the council and or any of its committees that resulted in such formal action were in meetings open to the public, in compliance with all legal requirements, including Section 121.22 of the Ohio Revised Code.

**Section 6.** Pursuant to Article 6.07(B) of the New Albany Charter, this ordinance shall become effective thirty (30) days after adoption.

**CERTIFIED AS ADOPTED** this \_\_\_\_\_ day of \_\_\_\_\_, 2026.

**Attest:**

\_\_\_\_\_  
Sloan T. Spalding  
Mayor

\_\_\_\_\_  
Jennifer H. Mason  
Clerk of Council

**Approved as to form:**

\_\_\_\_\_  
Benjamin S. Albrecht  
Law Director

**Legislation dates:**

Prepared: 03/27/2026

Introduced: 04/07/2026

Revised:

Adopted:

Effective:



**ORDINANCE O-12-2026**

**AN ORDINANCE TO AMEND THE ZONING ORDINANCE OF THE CITY OF NEW ALBANY BY AMENDING THE ZONING MAP TO REZONE 69.654 +/- ACRES OF LAND GENERALLY LOCATED AT THE INTERSECTION OF EAST WALNUT STREET AND BEVELHYMER ROAD FROM ITS CURRENT ZONING OF “AG” AGRICULTURAL DISTRICT TO “CF” COMMUNITY FACILITIES AS REQUESTED BY THE CITY OF NEW ALBANY C/O EMH&T**

**WHEREAS**, the council of the city of New Albany has determined that it is necessary to rezone certain property located within the city to promote orderly growth and development of lands; and

**WHEREAS**, the Rocky Fork-Blacklick Accord, New Albany Planning Commission, and New Albany City Council on separate occasions have held public hearings and received public input into the amendment of the zoning ordinance; and

**WHEREAS**, pursuant to the application by the city of New Albany c/o EMH&T, the New Albany Planning Commission reviewed the proposed zoning amendment and recommended its approval on April 7, 2026 (ZC-05-2026).

**NOW, THEREFORE, BE IT ORDAINED** by council for the city of New Albany, counties of Franklin and Licking, State of Ohio, that:

**Section 1.** Council hereby amends the zoning ordinance map of the city of New Albany to change the zoning classification of the following described site:

- A. An approximately 69.654 +/- acre site within Franklin County, generally located at the intersection of East Walnut Street and Bevelhymer Road from its current zoning of Agricultural District (AG) to Community Facilities (CF).
- B. The zoning district’s boundary map and development plan are hereby attached and marked Exhibit A.

**Section 2.** It is hereby found and determined that all formal actions of this council concerning and relating to the adoption of this legislation were adopted in an open meeting of council, and that all deliberations of the council and or any of its committees that resulted in such formal action were in meetings open to the public, in compliance with Section 121.22 of the Ohio Revised Code.

**Section 3.** Pursuant to Article 6.07(B) of the New Albany Charter, this ordinance shall become effective thirty (30) days after adoption.

CERTIFIED AS ADOPTED this \_\_\_\_\_ day of \_\_\_\_\_, 2026.

Attest:

\_\_\_\_\_  
Sloan T. Spalding  
Mayor

\_\_\_\_\_  
Jennifer H. Mason  
Clerk of Council

**Approved as to form:**

\_\_\_\_\_  
Benjamin S. Albrecht  
Law Director

**Legislation dates:**

Prepared: 04/06/2026

Introduced: 04/21/2026

Revised:

Adopted:

Effective:

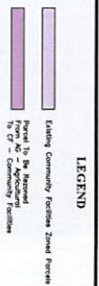
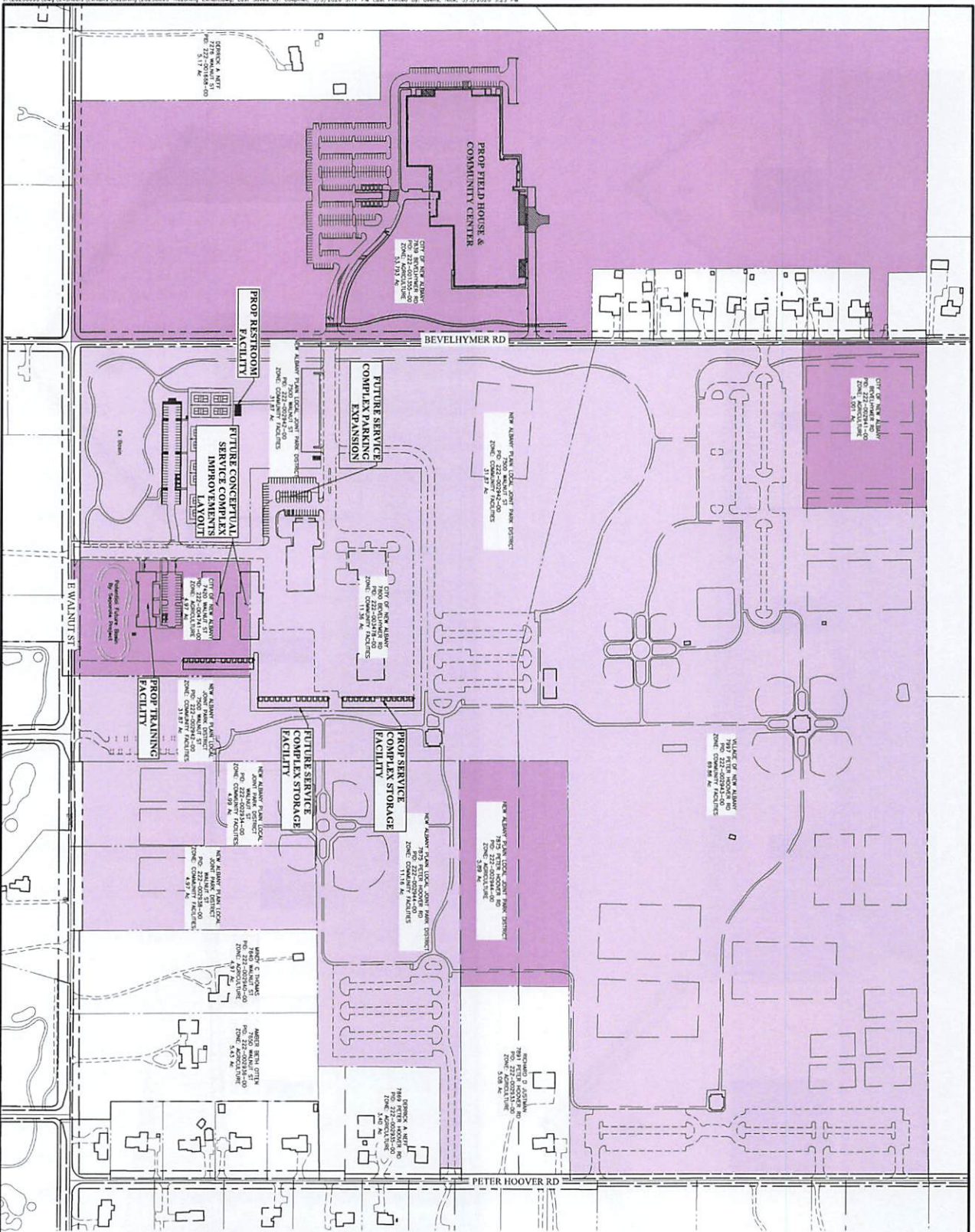

**EXHIBIT A - O-12-2026**

<p>DATE: March 3, 2026</p> <p>SCALE: 1" = 100'</p> <p>PROJECT: 2025-0895</p> <p>SHEET: 2/14</p>	<p><b>EMHT</b> Eagle, McWhorter, Hamilton &amp; Blinn, Inc. 2000 New Albany Road, Columbus, Ohio 43260 Phone: 614.771.1200</p>	<p>CITY OF NEW ALBANY, FRANKLIN COUNTY, OHIO</p> <p>EXHIBIT FOR</p> <p><b>CITY OF NEW ALBANY</b></p> <p><b>EAST WALNUT STREET</b></p> <p><b>REZONING EXHIBIT</b></p>	<p>CITY OF NEW ALBANY</p>	<p>REVISIONS</p> <table border="1"> <thead> <tr> <th>MARK</th> <th>DATE</th> <th>DESCRIPTION</th> </tr> </thead> <tbody> <tr> <td> </td> <td> </td> <td> </td> </tr> <tr> <td> </td> <td> </td> <td> </td> </tr> <tr> <td> </td> <td> </td> <td> </td> </tr> </tbody> </table>	MARK	DATE	DESCRIPTION									
				MARK	DATE	DESCRIPTION										

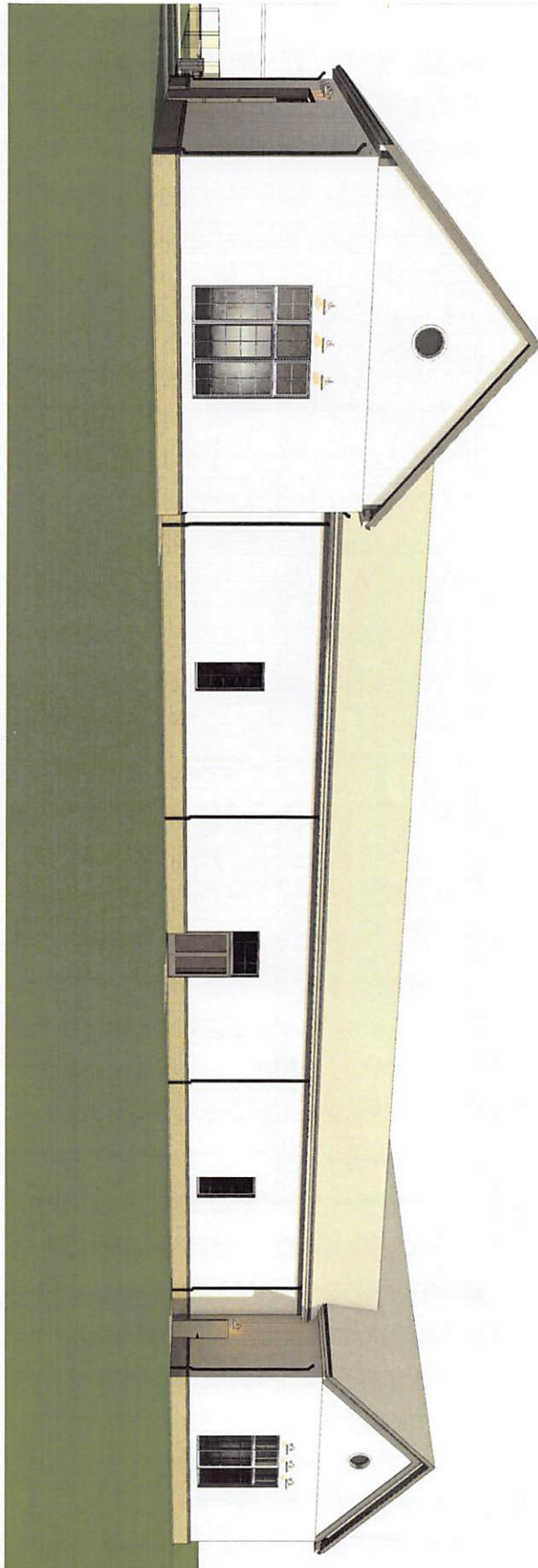
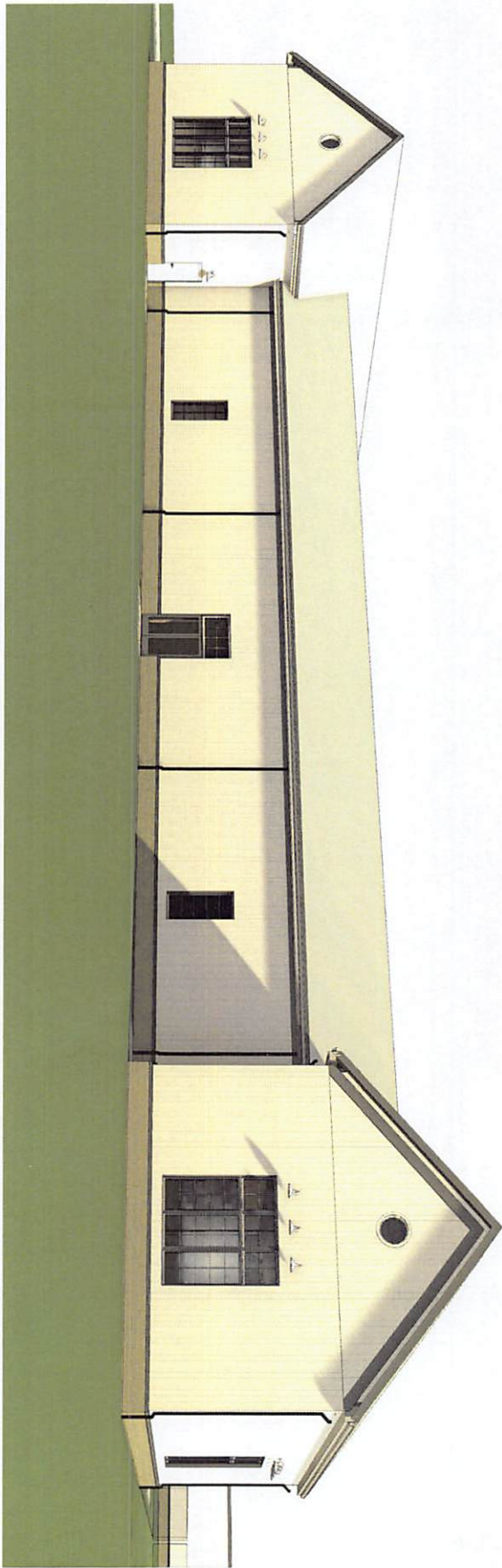

# NEW ALBANY POLICE TRAINING FACILITY

7800 BEVELHYMER ROAD  
NEW ALBANY, OHIO 43054



All drawings and written material appearing herein constitute the original and unpublished work of the architect and the same may not be duplicated, used or disclosed without the written consent of the architect.



G102

3D VIEWS

3D ART: JASON PETERSON  
ARCHITECT: JAMES R. KING  
DATE: 05/25/12

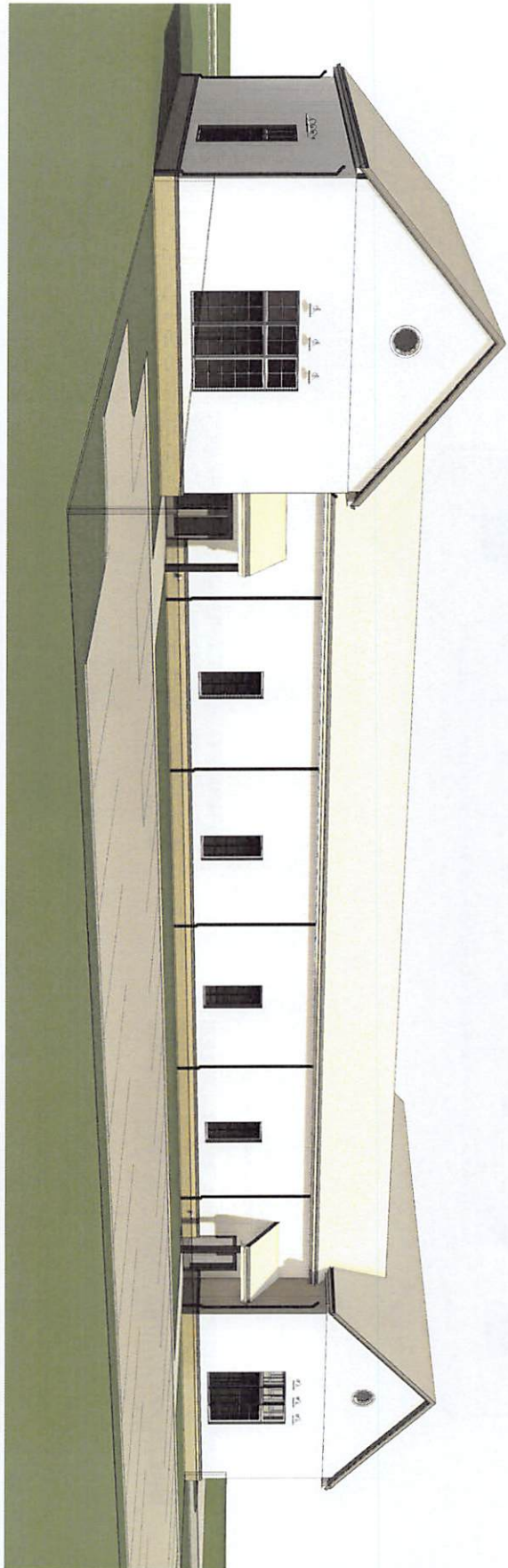

G104

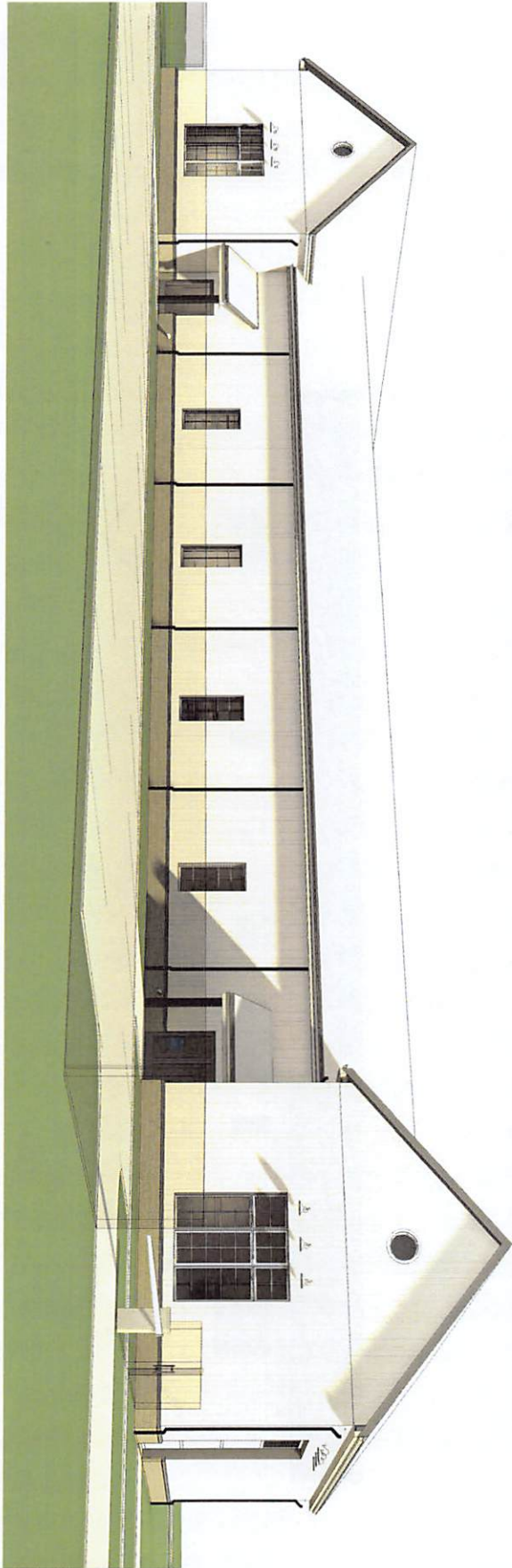

G103

**NEW ALBANY POLICE TRAINING FACILITY**

7800 BEVELHYMER ROAD  
NEW ALBANY, OHIO 43054



All drawings and written material appearing herein constitute the original and unpublished work of the architect and the same may not be duplicated, used or disclosed without the written consent of the architect.



G103

3D VIEWS

ARCHITECT  
JAMES R. KING  
ARCHITECTS



**EXTERIOR FINISHES**

METAL ROOF	200 SPAN/200 BL-20	COLOR: DYNACLAD WEATHERED ZINC
ALUMINUM GUTTERS & DOWNSPOUTS	200	COLOR: DYNACLAD WEATHERED ZINC
VERTICAL METAL SIDING	200 R-PANEL WP/P	COLOR: DYNACLAD WEATHERED ZINC
SPIT-FACED BLOCK & WATER TABLE	DECEYR DS	COLOR: NATURAL GRAY
	MORTAR: CEMEX	COLOR: 501 LIMESTONE
ENTRY DOORS & WINDOWS	RAMMEER	COLOR: BONE WHITE
OVERHEAD DOOR CO.	TRIMMOORE 800	COLOR: WHITE
GARAGE DOOR(S)	UPPER & LOWER	

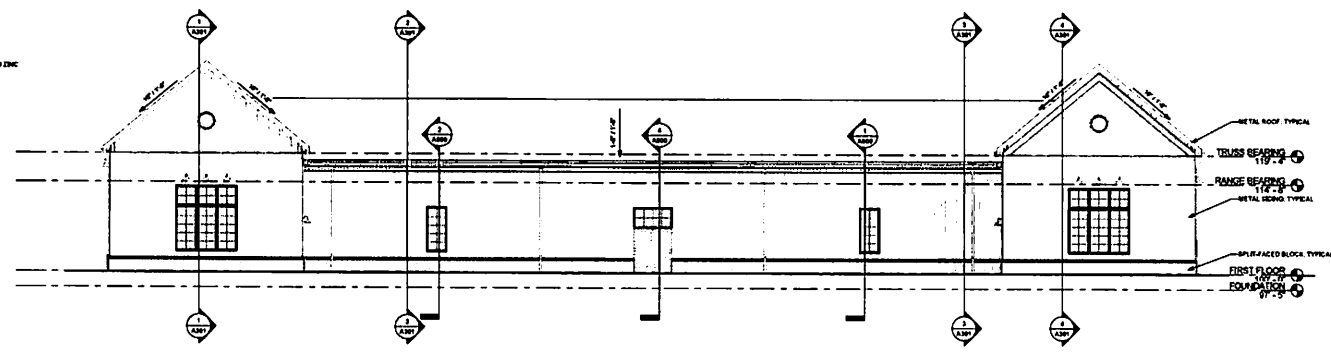

① SOUTH ELEVATION  
118' x 112'

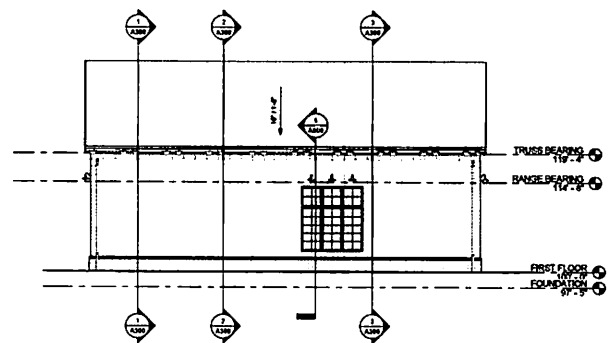

② EAST ELEVATION  
118' x 112'

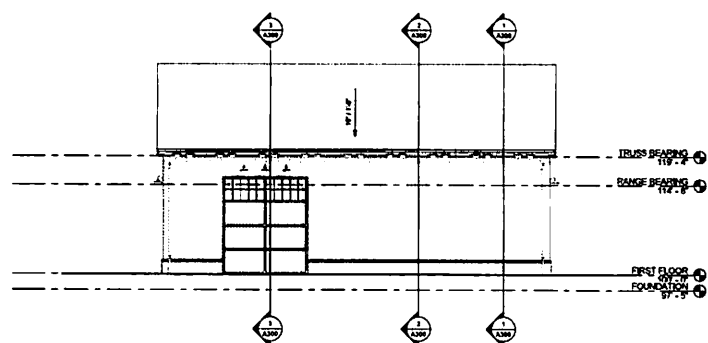

③ WEST ELEVATION  
118' x 112'

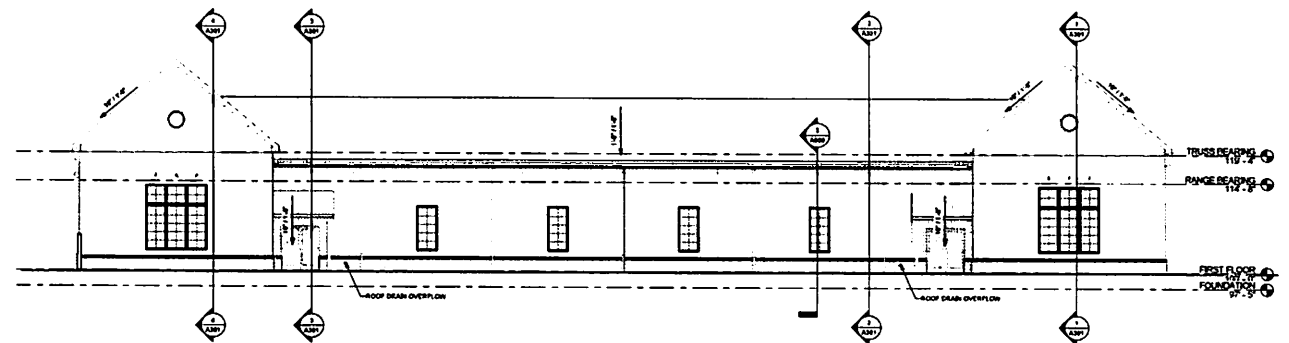

④ NORTH ELEVATION  
118' x 112'



All drawings and written material appearing herein constitute the original and unpublished work of the architect and the same may not be duplicated, used or disclosed without the written consent of the architect.



**NEW ALBANY POLICE TRAINING FACILITY**

7800 BEVELHYMER ROAD  
NEW ALBANY, OHIO 43054

30 SET 1006/020  
ADD PRELIM SET 801/020  
ADD REVISED SET 800/020

EXTERIOR ELEVATIONS

**A200**

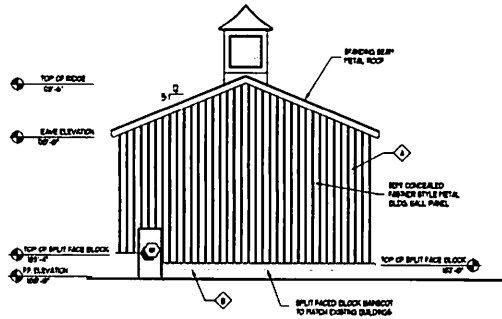

**A** SIDE ELEVATION  
SCALE: 1/8" = 1'-0"

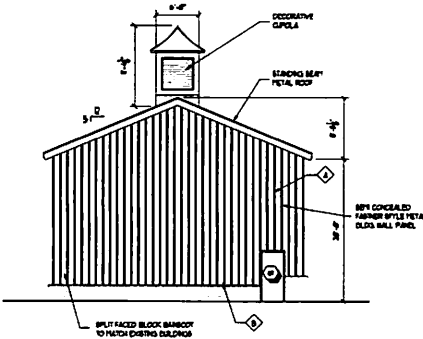

**B** SIDE ELEVATION  
SCALE: 1/8" = 1'-0"

COLOR SCHEDULE		
SYMBOL	DESCRIPTION	COLOR
◆	SP1 CONCEALED FARMER STYLE PETA. GLDZ WALL PANEL	SP1ELOW 848 - SP1 CONCEALED FARMER STYLE SP1ELOW FACE WALL BY BRAND COLOR - "REGAL WHITE"
◆	SP1 FACED BLOCK BARNDOOR	WOODGRAIN BLOCK COGNAC - PLEASE ASK BECK COLOR ALUMINUM ROOFING
◆	SP1 FACED FARMER STYLE PETA. ROOF	SP1ELOW 848 - SP1 CONCEALED FARMER STYLE PETA. ROOF PANELS BY BRAND COLOR - "VALHALLA PINE"
◆	ALPHABET WINDOWS & DOORS	SP1ELOW 848 SERIES 17 COMMERCIAL GRADE WINDOWS & DOORS COLOR SURE WHITE
◆	PETA. OVERHEAD DOOR	OVERHEAD DOOR CO - SERIES STEEL MELANET SECTIONAL DOOR COLOR 848

NOTE: PETA. ROOF & FARMING COLORS SHALL MATCH WALL PANEL COLORS. VERIFY BY ARCHITECT PRIOR TO ORDERING.

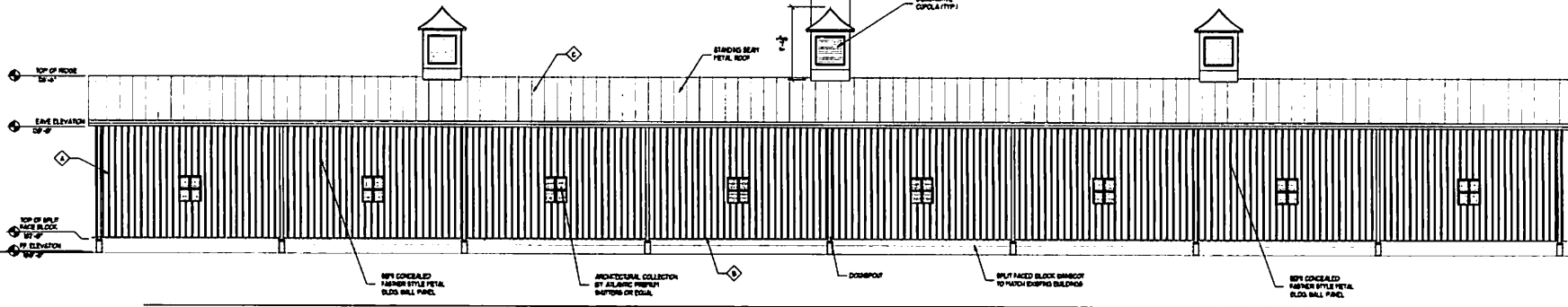

**C** SIDE ELEVATION  
SCALE: 1/8" = 1'-0"

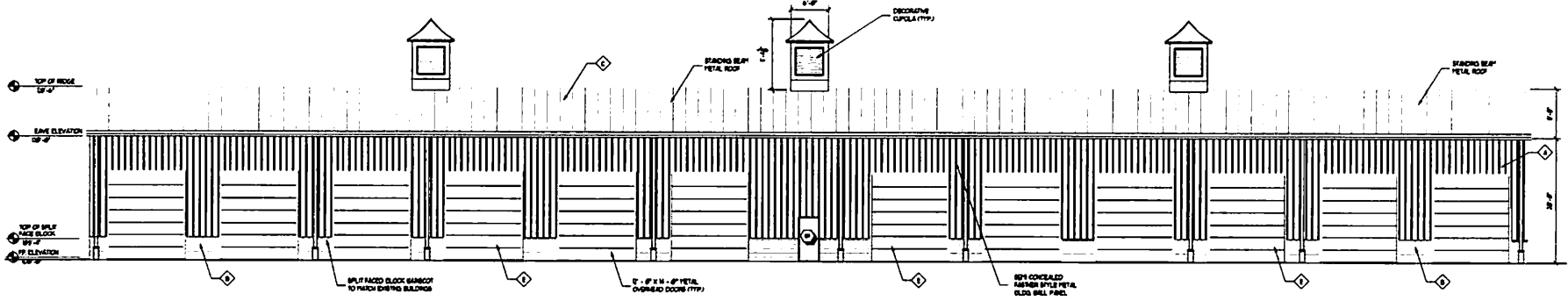

**D** SIDE ELEVATION  
SCALE: 1/8" = 1'-0"

WE WARRANT AND THE ARCHITECT, ENGINEER, ARCHITECT, CONTRACTOR, AND SUPPLIER SHALL BE RESPONSIBLE FOR THE DESIGN AND CONSTRUCTION OF THE PROJECT. WE SHALL BE RESPONSIBLE FOR THE DESIGN AND CONSTRUCTION OF THE PROJECT. WE SHALL BE RESPONSIBLE FOR THE DESIGN AND CONSTRUCTION OF THE PROJECT.

**PROJECT PHASE**  
 PRELIMINARY  
 PERMISSIVE/CONTRACT  
 CONTRACT DOCUMENTS  
 PERMIT DOCUMENTS  
 CONSTRUCTION SET BEING  
 AS-BUILT SETS

**MUNICIPAL SERVICE FACILITY**  
 CONSTRUCTION OF NEW STORAGE BUILDING  
 7000 SEVENHILLS ROAD  
 NEW ALBANY, OHIO 43054  
**VILLAGE OF NEW ALBANY, OHIO**  
 80 WEST MAIN STREET  
 NEW ALBANY, OHIO 43054  
 E.O. 14176



Ronald J. Gajoch, License #22-0078  
 Expiration Date December 31, 2025

**RONALD J. GAJOCH & ASSOCIATES, INC.**  
 ARCHITECTS & PLANNERS

**RONALD J. GAJOCH & ASSOCIATES INC.**  
 545 METRO PLACE SOUTH  
 SUITE 400  
 DUBLIN, OHIO 43007-3388  
 PHONE: 614-793-4871  
 FAX: 614-793-4821

PROJECT NO.: **VA000725**

DATE: **JANUARY 30, 2026**

- REVISIONS
- ▲
  - ▲
  - ▲
  - ▲
  - ▲
  - ▲
  - ▲

SHEET NO.

**A-21**





**ORDINANCE O-13-2026**

**AN ORDINANCE TO AMEND CHAPTER 1159.11 OF THE PLANNING AND ZONING CODE OF THE CITY OF NEW ALBANY CODIFIED ORDINANCES AS REQUESTED BY THE CITY OF NEW ALBANY**

**WHEREAS**, it has been found that the codified ordinances of the city of New Albany, Chapter 1159 needs to be amended; and

**WHEREAS**, New Albany City Council has determined that it is necessary to amend the codified ordinances of the city of New Albany to ensure approved development plans move forward in a timely manner consistent with adopted plans and policies; and

**WHEREAS**, the amendment will provide greater clarity, predictability, and a limited-extension framework to establish consistent review standards, allowing flexibility for circumstances beyond an applicant's control; and

**WHEREAS**, the Planning Commission has held a public hearing on the amendment and recommended approval of the proposed amendment to the codified ordinance at its meeting on March 16, 2026.

**NOW, THEREFORE, BE IT ORDAINED** by council for the city of New Albany, counties of Franklin and Licking, State of Ohio, that:

**Section 1.** Portions of Codified Ordinance Chapter 1159.11 shall be amended as set forth in Exhibit A, which depicts these amendments in colored ink.

**Section 2.** It is hereby found and determined that all formal actions of this council concerning and relating to the adoption of this legislation were adopted in an open meeting of council, and that all deliberations of the council and or any of its committees that resulted in such formal action were in meetings open to the public, in compliance with Section 121.22 of the Ohio Revised Code.

**Section 3.** Pursuant to Article 6.07(B) of the New Albany Charter, this ordinance shall become effective thirty (30) days after adoption.

**CERTIFIED AS ADOPTED** this \_\_\_\_\_ day of \_\_\_\_\_, 2026.

**Attest:**

\_\_\_\_\_  
Sloan T. Spalding  
Mayor

\_\_\_\_\_  
Jennifer H. Mason  
Clerk of Council

**Approved as to form:**

\_\_\_\_\_  
Benjamin S. Albrecht  
Interim Law Director

**Legislation dates:**

Prepared: 04/06/2026

Introduced: 04/21/2026

Revised:

Adopted:

Effective:

---

**CHAPTER 1159 PUD PLANNED UNIT DEVELOPMENT DISTRICT<sup>1</sup>**

**1159.11 RECORDING AND TRANSFER.**

(a) Final Plat: When a final plat is approved by Council, the owner shall file and record the same in the Office of the County Recorder within twelve (12) months unless such time is, for good cause shown, extended by resolution of Council. If not recorded within this time, the approval of Council shall become null and void.

(b) Final Development Plan: If construction is not begun within two (2) years of approval of the Final Development Plan, all approvals and permits shall be invalidated and canceled. Original tracings will become the permanent record of the County Recorder. One copy of this tracing, reproduced on mylar, showing the date and place of recording, shall be supplied by the owner to Council as local public records. Such two (2) year period may be extended by the Commission for good cause. The applicant may request a one-time timeframe extension for one (1) year by the Commission, if the applicant has documented in-writing one of the following: a) Financial issues that would alter the expected FDP timeline; b) Delay in acquiring a required building or utility permit necessary to carry out the provisions of the FDP; c) Presence of an environmental or other public safety issues; d) Other unique reasons deemed as permissible by the Commission.

(Ord. 44-97. Passed 12-16-97; Ord. 25-2007. Passed 7-10-07.)

---

<sup>1</sup>Cross reference(s)—District established - see P. & Z. 1125.01



## RESOLUTION R-10-2026

### A RESOLUTION TO AUTHORIZE THE CITY OF NEW ALBANY TO PARTICIPATE IN THE ODOT ROAD SALT CONTRACTS AWARDED IN 2026

**WHEREAS**, the City of New Albany, Franklin and Licking Counties, hereby submits this written agreement to participate in the Ohio Department of Transportation's (ODOT) annual road salt bid in accordance with Ohio Revised Code 5513.01(B) and hereby agrees to all of the following terms and conditions in its participation of the ODOT road salt contract:

- A. The City of New Albany hereby agrees to be bound by all terms and conditions established by ODOT in the road salt contract and acknowledges that upon award of the contract by the director of ODOT it shall be bound by all such terms and conditions included in the contract; and
- B. The City of New Albany hereby acknowledges that upon the director of ODOT's signing of the road salt contract, it shall effectively form a contract between the awarded salt supplier and the City of New Albany; and
- C. The City of New Albany agrees to be solely responsible for resolving all claims or disputes arising out of its participation in the ODOT road salt contract and agrees; and
- D. The City of New Albany's electronic order for sodium chloride (road salt) will be the amount the City of New Albany agrees to purchase from its awarded salt supplier at the delivered bid price per ton awarded by the Director of ODOT; and
- E. The City of New Albany hereby agrees to purchase a minimum of 85% of its electronically submitted salt quantities from its awarded salt supplier during the contract's effective period; and
- F. The City of New Albany hereby agrees to place orders with and directly pay the awarded salt supplier on a net 30 basis for all road salt it receives pursuant to ODOT salt contract; and
- G. The City of New Albany acknowledges that should it wish to rescind this participation agreement it will do so by written, emailed request by no later than Friday, May 1, 2026 by 5:00 p.m. The written, emailed request to rescind this participation agreement must be received by the ODOT Office of Contract Sales, Purchasing Section email: [Contracts.Purchasing@dot.ohio.gov](mailto:Contracts.Purchasing@dot.ohio.gov) by the deadline. The department, upon receipt, will respond that it has received the request and that it has effectively removed the city's participation request. Furthermore, it is the sole responsibility of the city to ensure ODOT has received this participation agreement as well as the receipt of any request to rescind this participation agreement. The department shall not be held responsible or liable for failure to receive the city's participation agreement and/or the city's request to rescind its participation agreement.

**NOW, THEREFORE, BE IT RESOLVED** by Council for the City of New Albany, Counties of Franklin and Licking, State of Ohio, that:

**Section 1.** The above participation agreement for the ODOT road salt contract is hereby approved, funding has been authorized, and the city of New Albany agrees to the above terms and conditions regarding participation in the ODOT salt contract.

**Section 2.** It is hereby found and determined that all formal actions of this council concerning and relating to the adoption of this legislation were adopted in an open meeting of the council, and that all deliberations of the council and or any of its committees that resulted in such formal action were in meetings open to the public, in compliance with all legal requirements, including Section 121.22 of the Ohio Revised Code.

**Section 3.** Pursuant to Article 6.07(A) of the New Albany Charter, this resolution shall take effect upon adoption.

**CERTIFIED AS ADOPTED** this \_\_\_\_\_ day of \_\_\_\_\_, 2026.

**Attest:**

\_\_\_\_\_  
Sloan T. Spalding  
Mayor

\_\_\_\_\_  
Jennifer H. Mason  
Clerk of Council

**Approved as to form:**

\_\_\_\_\_  
Benjamin S. Albrecht  
Law Director

**Legislation dates:**

Prepared: 04/08/2026

Introduced: 04/21/2026

Revised:

Adopted:

Effective: