



ORDINANCE O-12-2026

AN ORDINANCE TO AMEND THE ZONING ORDINANCE OF THE CITY OF NEW ALBANY BY AMENDING THE ZONING MAP TO REZONE 69.654 +/- ACRES OF LAND GENERALLY LOCATED AT THE INTERSECTION OF EAST WALNUT STREET AND BEVELHYMER ROAD FROM ITS CURRENT ZONING OF "AG" AGRICULTURAL DISTRICT TO "CF" COMMUNITY FACILITIES AS REQUESTED BY THE CITY OF NEW ALBANY C/O EMH&T

WHEREAS, the council of the city of New Albany has determined that it is necessary to rezone certain property located within the city to promote orderly growth and development of lands; and

WHEREAS, the Rocky Fork-Blacklick Accord, New Albany Planning Commission, and New Albany City Council on separate occasions have held public hearings and received public input into the amendment of the zoning ordinance; and

WHEREAS, pursuant to the application by the city of New Albany c/o EMH&T, the New Albany Planning Commission reviewed the proposed zoning amendment and recommended its approval on April 7, 2026 (ZC-05-2026).

NOW, THEREFORE, BE IT ORDAINED by council for the city of New Albany, counties of Franklin and Licking, State of Ohio, that:

Section 1. Council hereby amends the zoning ordinance map of the city of New Albany to change the zoning classification of the following described site:

- A. An approximately 69.654 +/- acre site within Franklin County, generally located at the intersection of East Walnut Street and Bevelhymer Road from its current zoning of Agricultural District (AG) to Community Facilities (CF).
- B. The zoning district's boundary map and development plan are hereby attached and marked Exhibit A.

Section 2. It is hereby found and determined that all formal actions of this council concerning and relating to the adoption of this legislation were adopted in an open meeting of council, and that all deliberations of the council and or any of its committees that resulted in such formal action were in meetings open to the public, in compliance with Section 121.22 of the Ohio Revised Code.

Section 3. Pursuant to Article 6.07(B) of the New Albany Charter, this ordinance shall become effective thirty (30) days after adoption.

CERTIFIED AS ADOPTED this 05 day of May, 2026.

Attest:

Sloan T. Spalding
Mayor

Jennifer H. Mason
Clerk of Council

Approved as to form:

Benjamin S. Albrecht
Law Director

Legislation dates:	
Prepared:	04/06/2026
Introduced:	04/21/2026
Revised:	
Adopted:	05/05/2026
Effective:	06/04/2026

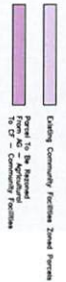
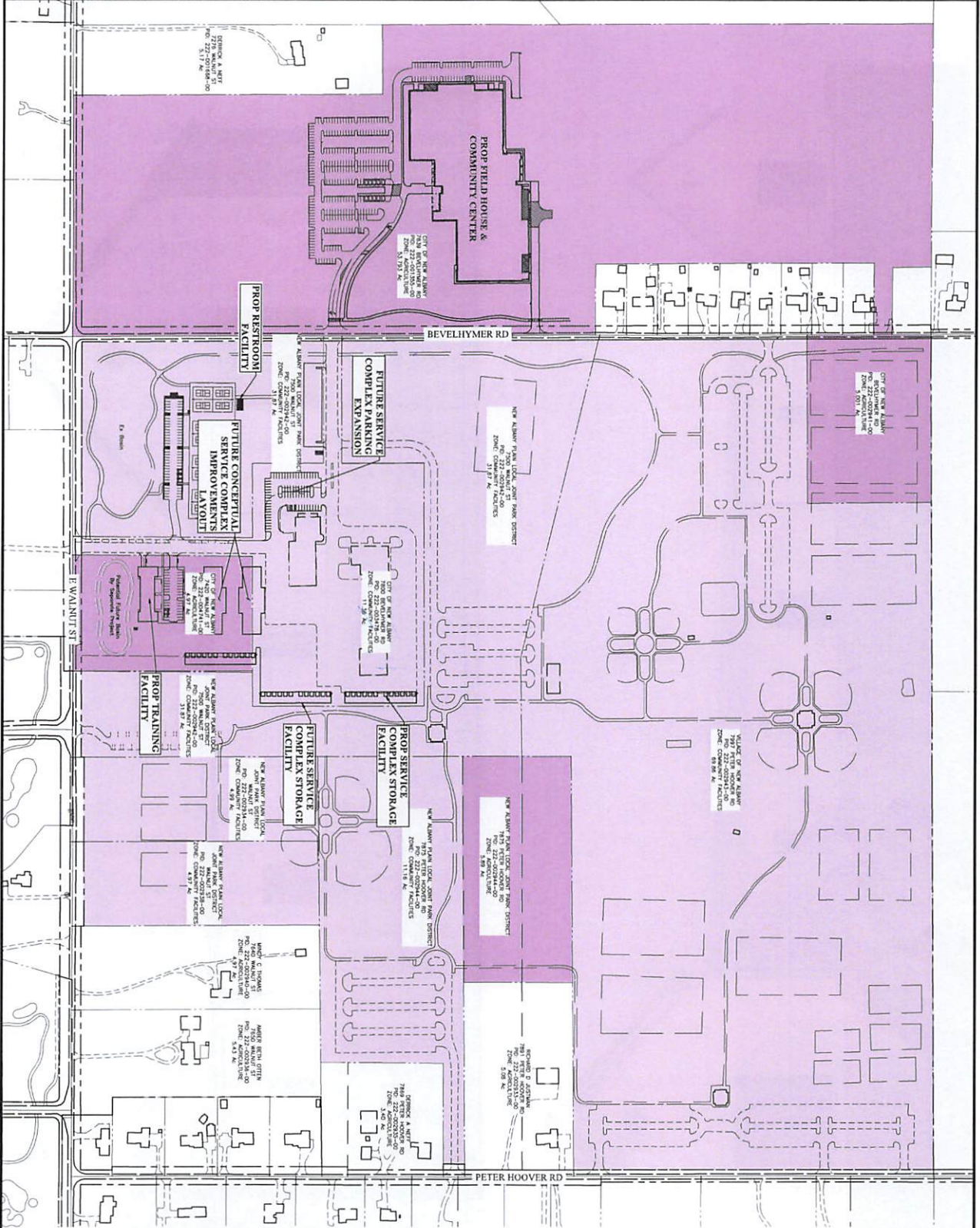

EXHIBIT A - O-12-2026



DATE: March 3, 2026
SCALE: 1" = 100'
JOB NO: 2025-0895
SHEET: 2/4

EMHT
Evans, Mechwart, Hamilton & Blum, Inc.
Engineers • Surveyors • Planners • Architects
1000 New Albany Avenue, Suite 200, Columbus, Ohio 43260
Phone: 614.771.2000
www.emht.com

CITY OF NEW ALBANY, FRANKLIN COUNTY, OHIO
EXHIBIT
FOR
**CITY OF NEW ALBANY
EAST WALNUT STREET
REZONING EXHIBIT**

CITY OF NEW ALBANY

REVISIONS	
MARK	DESCRIPTION

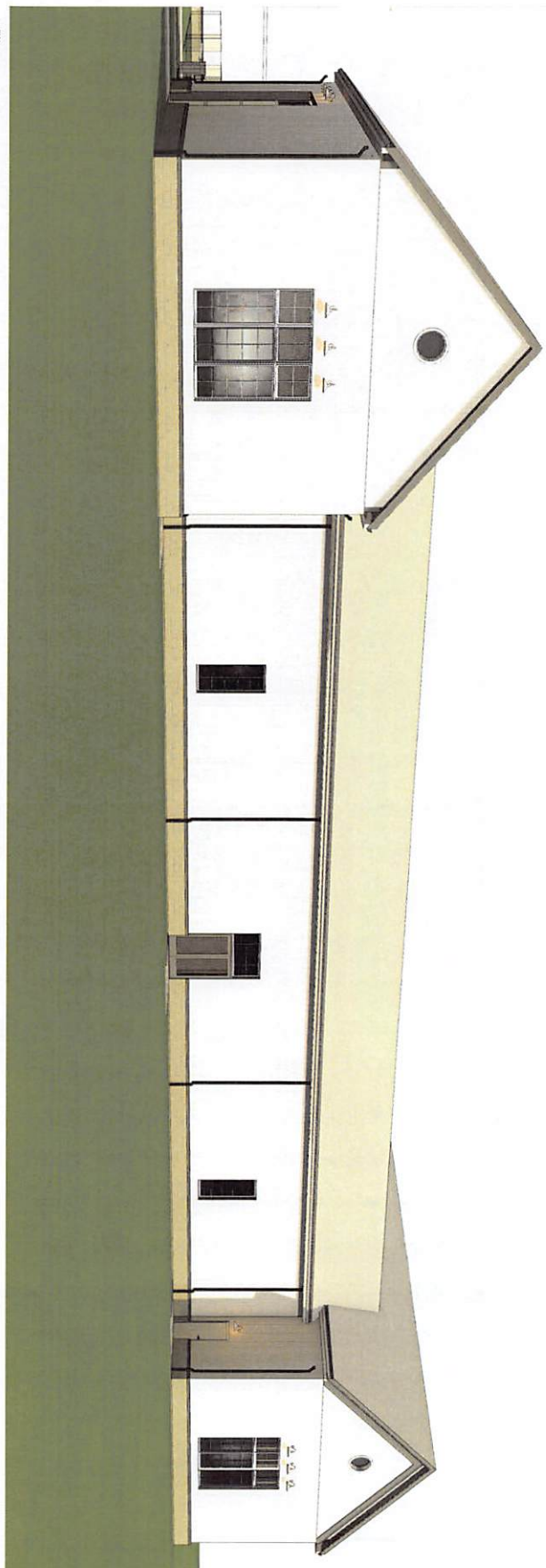
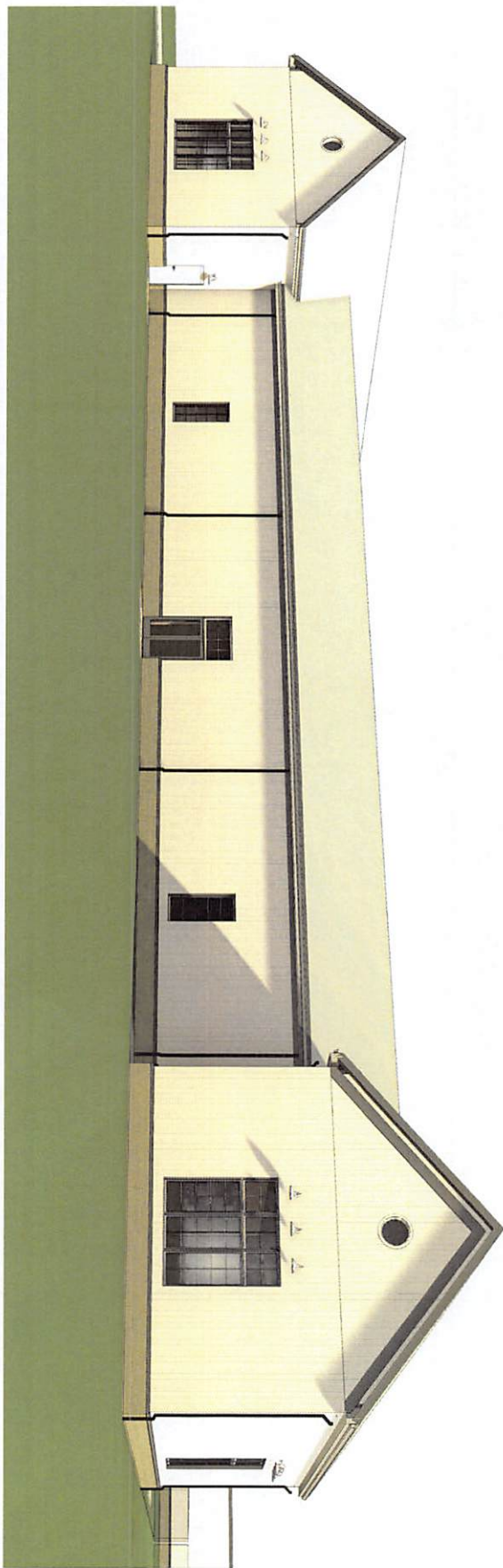

G102

3D VIEWS

30 ST
 11 ST
 14th Ave
 15th Ave
 16th Ave
 17th Ave
 18th Ave
 19th Ave
 20th Ave
 21st Ave
 22nd Ave
 23rd Ave
 24th Ave
 25th Ave
 26th Ave
 27th Ave
 28th Ave
 29th Ave
 30th Ave
 31st Ave
 32nd Ave
 33rd Ave
 34th Ave
 35th Ave
 36th Ave
 37th Ave
 38th Ave
 39th Ave
 40th Ave
 41st Ave
 42nd Ave
 43rd Ave
 44th Ave
 45th Ave
 46th Ave
 47th Ave
 48th Ave
 49th Ave
 50th Ave
 51st Ave
 52nd Ave
 53rd Ave
 54th Ave
 55th Ave
 56th Ave
 57th Ave
 58th Ave
 59th Ave
 60th Ave
 61st Ave
 62nd Ave
 63rd Ave
 64th Ave
 65th Ave
 66th Ave
 67th Ave
 68th Ave
 69th Ave
 70th Ave
 71st Ave
 72nd Ave
 73rd Ave
 74th Ave
 75th Ave
 76th Ave
 77th Ave
 78th Ave
 79th Ave
 80th Ave
 81st Ave
 82nd Ave
 83rd Ave
 84th Ave
 85th Ave
 86th Ave
 87th Ave
 88th Ave
 89th Ave
 90th Ave
 91st Ave
 92nd Ave
 93rd Ave
 94th Ave
 95th Ave
 96th Ave
 97th Ave
 98th Ave
 99th Ave
 100th Ave

NEW ALBANY POLICE TRAINING FACILITY

7800 BEVELHYMER ROAD
 NEW ALBANY, OHIO 43054



All drawings and written material appearing herein constitute the original and unpublished work of the architect and the same may not be duplicated, used or disclosed without the written consent of the architect.



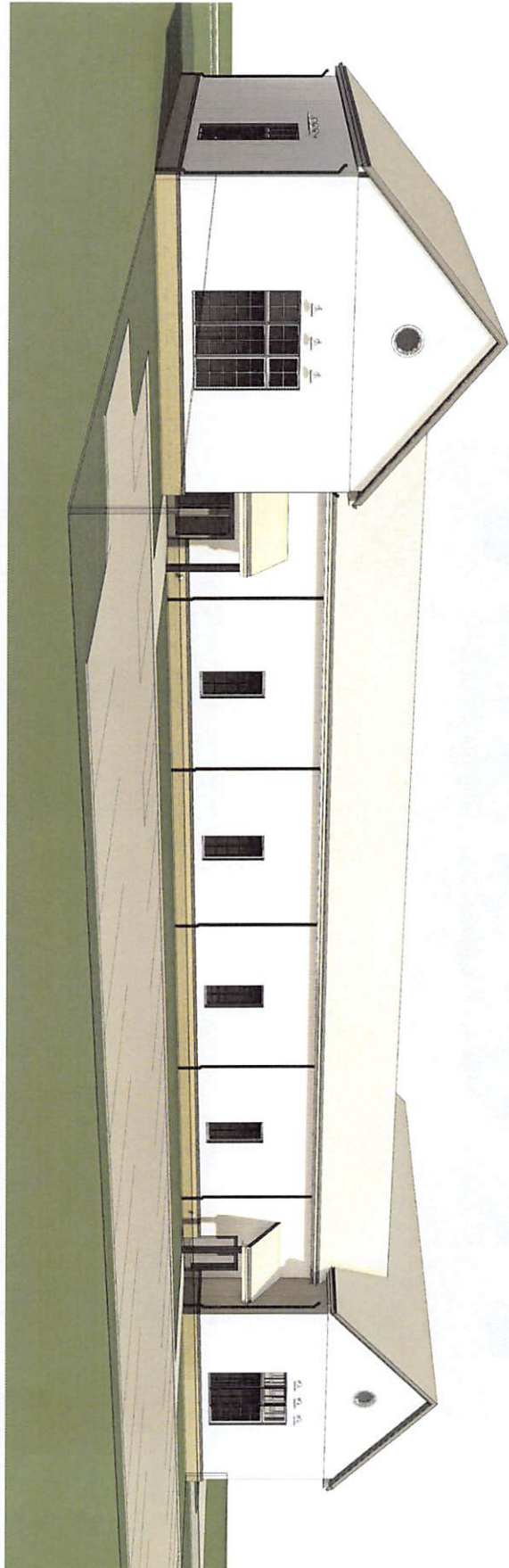

G104

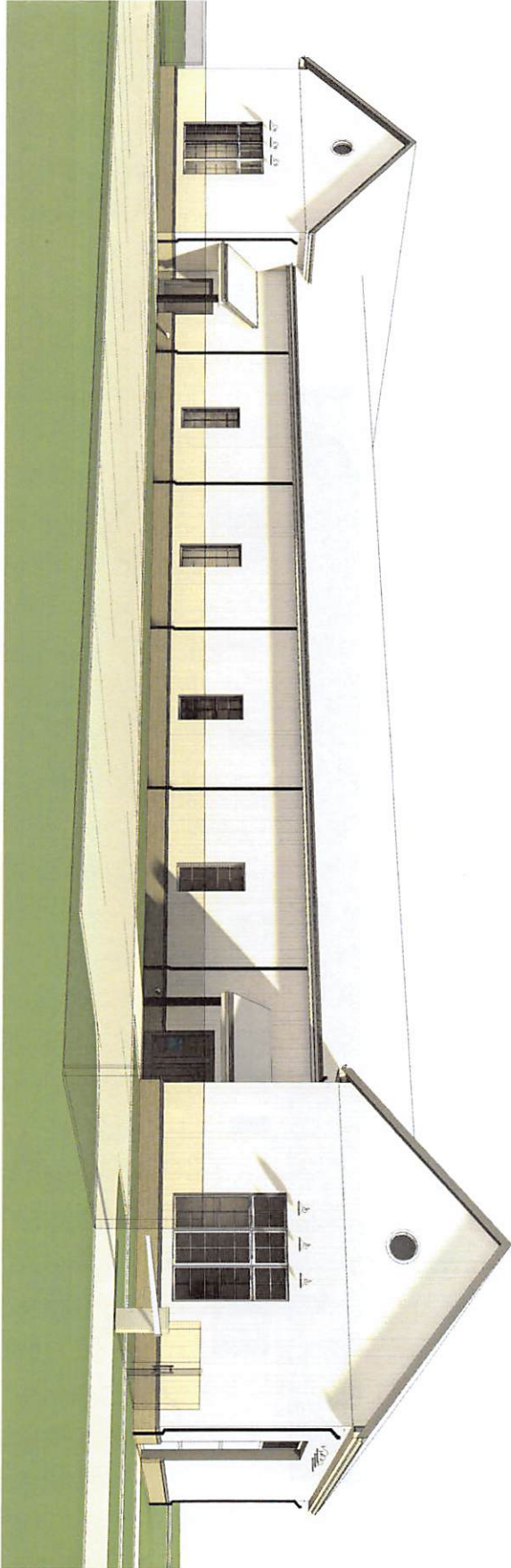

G103

NEW ALBANY POLICE TRAINING FACILITY

7800 BEVELHYMER ROAD
NEW ALBANY, OHIO 43054



All drawings and written material appearing herein constitute the original and unpublished work of the architect and the same may not be duplicated, used or disclosed without the written consent of the architect.



G103

3D VIEWS

DATE: 10/20/14
DRAWN BY: J. KING
CHECKED BY: J. KING
SCALE: AS SHOWN

EXTERIOR PROJECT
 NEW ALBANY POLICE TRAINING FACILITY
 ARCHITECT: HORNE & KING ARCHITECTS
 10000 WOODBURN ROAD, NEW ALBANY, OHIO 43054
 DATE: 08/11/11
 DRAWN BY: J. KING
 CHECKED BY: J. KING
 PROJECT NO.: 11-001

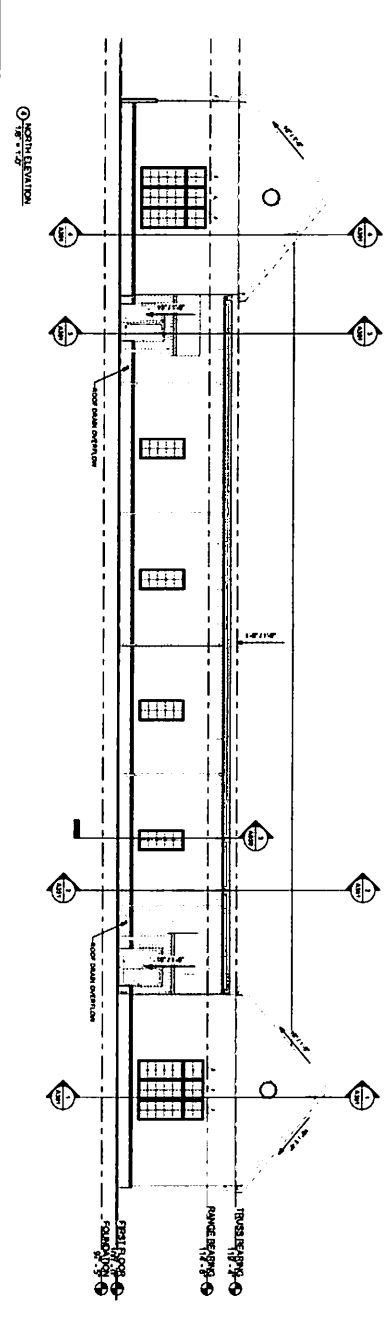
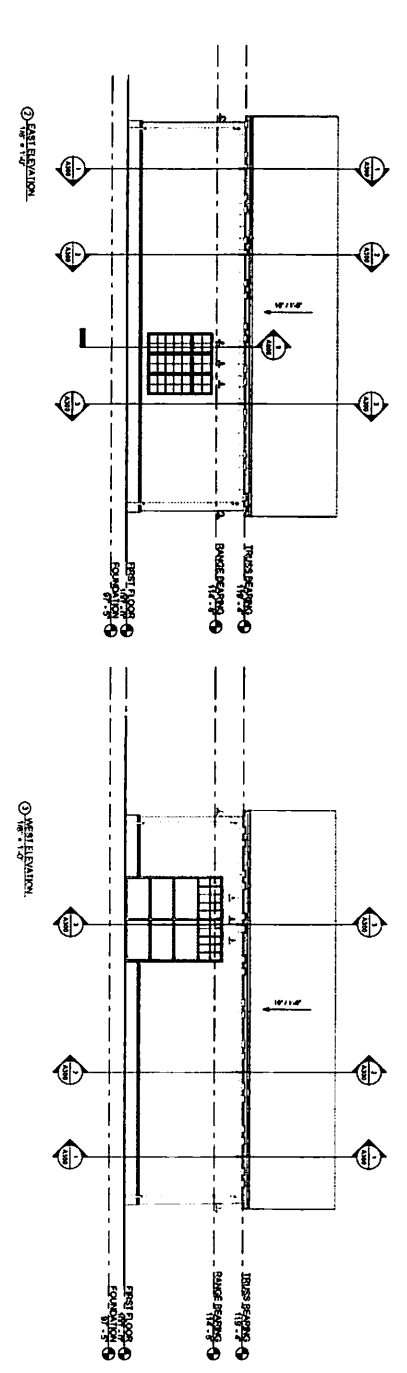
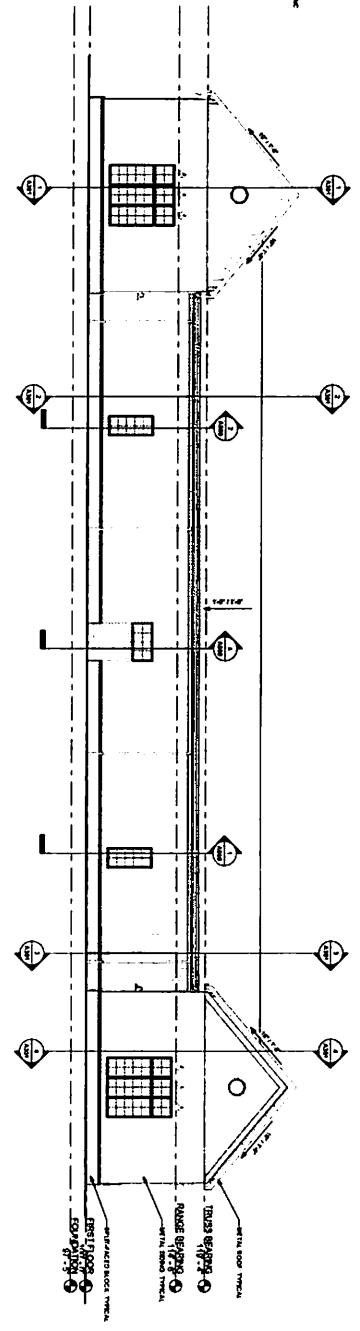

A200 EXTERIOR ELEVATIONS	NEW ALBANY POLICE TRAINING FACILITY	7800 BEVELHYMER ROAD NEW ALBANY, OHIO 43054		All drawings and written material appearing herein constitute the original and unpublished work of the architect and the same may not be duplicated, used or disclosed without the written consent of the architect.	HORNE & KING architects
	DRAWN BY: J. KING CHECKED BY: J. KING DATE: 08/11/11				

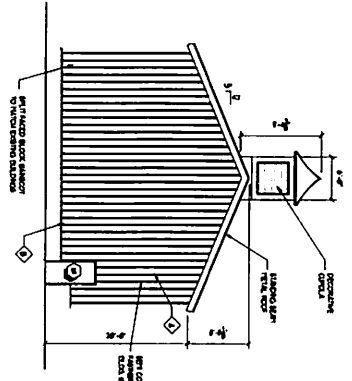
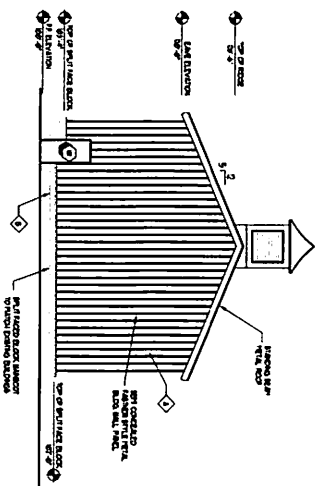

COLOR SCHEDULE		
SYMBOL	DESCRIPTION	COLOR
①	NET COLORED BRICK	BRICK
②	NET COLORED BRICK	BRICK
③	NET COLORED BRICK	BRICK
④	NET COLORED BRICK	BRICK
⑤	NET COLORED BRICK	BRICK
⑥	NET COLORED BRICK	BRICK
⑦	NET COLORED BRICK	BRICK
⑧	NET COLORED BRICK	BRICK
⑨	NET COLORED BRICK	BRICK
⑩	NET COLORED BRICK	BRICK
⑪	NET COLORED BRICK	BRICK
⑫	NET COLORED BRICK	BRICK
⑬	NET COLORED BRICK	BRICK
⑭	NET COLORED BRICK	BRICK
⑮	NET COLORED BRICK	BRICK
⑯	NET COLORED BRICK	BRICK
⑰	NET COLORED BRICK	BRICK
⑱	NET COLORED BRICK	BRICK
⑲	NET COLORED BRICK	BRICK
⑳	NET COLORED BRICK	BRICK
㉑	NET COLORED BRICK	BRICK
㉒	NET COLORED BRICK	BRICK
㉓	NET COLORED BRICK	BRICK
㉔	NET COLORED BRICK	BRICK
㉕	NET COLORED BRICK	BRICK
㉖	NET COLORED BRICK	BRICK
㉗	NET COLORED BRICK	BRICK
㉘	NET COLORED BRICK	BRICK
㉙	NET COLORED BRICK	BRICK
㉚	NET COLORED BRICK	BRICK
㉛	NET COLORED BRICK	BRICK
㉜	NET COLORED BRICK	BRICK
㉝	NET COLORED BRICK	BRICK
㉞	NET COLORED BRICK	BRICK
㉟	NET COLORED BRICK	BRICK
㊱	NET COLORED BRICK	BRICK
㊲	NET COLORED BRICK	BRICK
㊳	NET COLORED BRICK	BRICK
㊴	NET COLORED BRICK	BRICK
㊵	NET COLORED BRICK	BRICK
㊶	NET COLORED BRICK	BRICK
㊷	NET COLORED BRICK	BRICK
㊸	NET COLORED BRICK	BRICK
㊹	NET COLORED BRICK	BRICK
㊺	NET COLORED BRICK	BRICK
㊻	NET COLORED BRICK	BRICK
㊼	NET COLORED BRICK	BRICK
㊽	NET COLORED BRICK	BRICK
㊾	NET COLORED BRICK	BRICK
㊿	NET COLORED BRICK	BRICK

NOTE: NET COLORED BRICK SHALL BE USED FOR ALL EXTERIOR WALLS UNLESS OTHERWISE SPECIFIED.

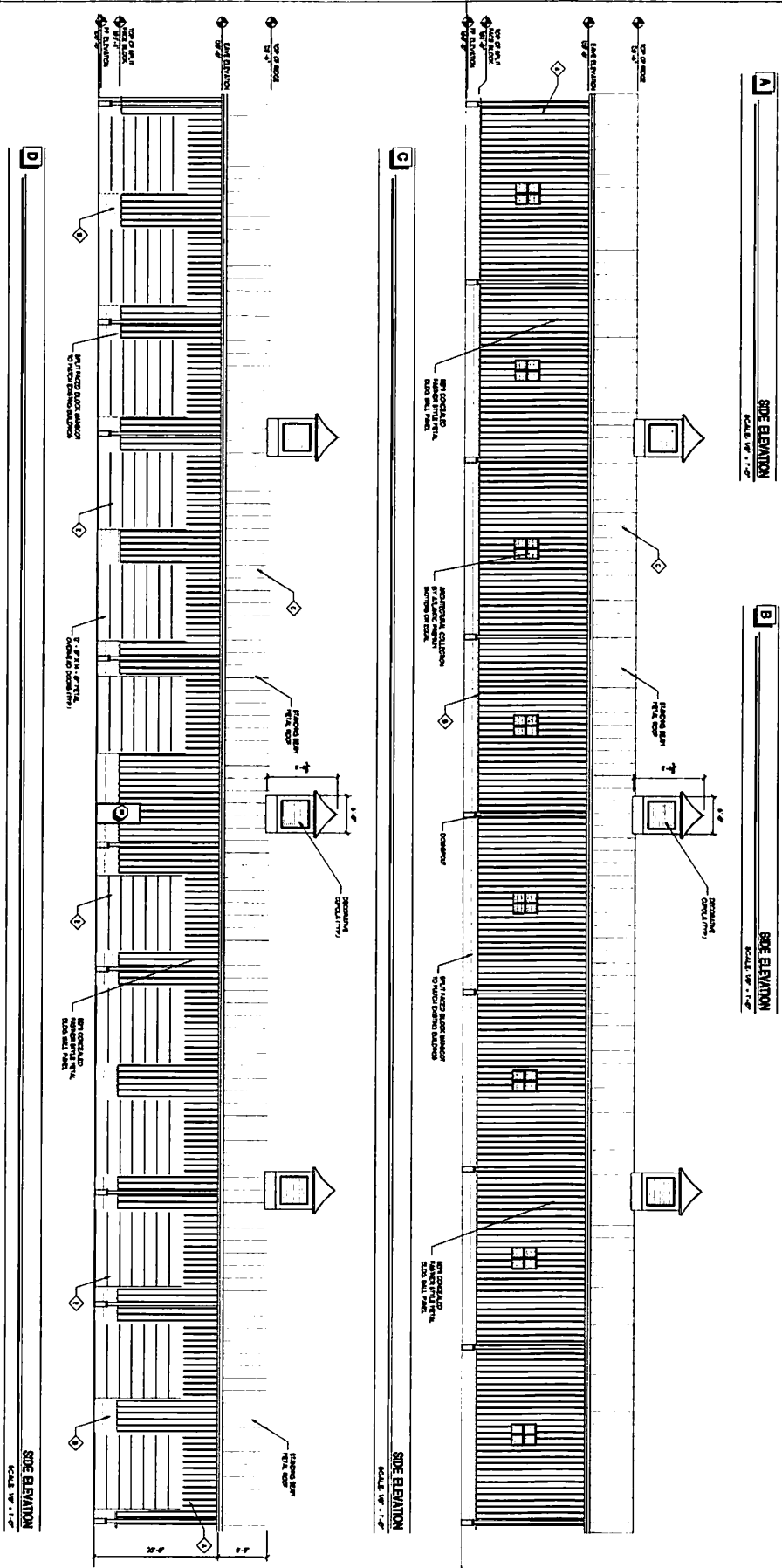

PROJECT NO. VAL02775
DATE: JANUARY 30, 2016
REVISIONS:

RONALD J. GAUCHI & ASSOCIATES, INC.
 ARCHITECTS
 646 METRO PLACE SOUTH
 SUITE 400
 DUBLIN, OHIO 43007-3388
 PHONE: 614-763-4811
 FAX: 614-763-4821

RONALD J. GAUCHI & ASSOCIATES, INC.
 7600 REVELLWOOD ROAD
 NEW ALBANY, OHIO 43054
 VILLAGE OF NEW ALBANY, OHIO
 9900 WEST MAIN STREET
 NEW ALBANY, OHIO 43054
 TEL: 614-855-0076
 FAX:

MUNICIPAL SERVICE FACILITY
 CONSTRUCTION OF NEW STORAGE BUILDING
 7600 REVELLWOOD ROAD
 NEW ALBANY, OHIO 43054

PROJECT NO. VAL02775
DATE: JANUARY 30, 2016
REVISIONS:

A-2.1



ORDINANCE O-13-2026

AN ORDINANCE TO AMEND CHAPTER 1159.11 OF THE PLANNING AND ZONING CODE OF THE CITY OF NEW ALBANY CODIFIED ORDINANCES AS REQUESTED BY THE CITY OF NEW ALBANY

WHEREAS, it has been found that the codified ordinances of the city of New Albany, Chapter 1159 needs to be amended; and

WHEREAS, New Albany City Council has determined that it is necessary to amend the codified ordinances of the city of New Albany to ensure approved development plans move forward in a timely manner consistent with adopted plans and policies; and

WHEREAS, the amendment will provide greater clarity, predictability, and a limited-extension framework to establish consistent review standards, allowing flexibility for circumstances beyond an applicant's control; and

WHEREAS, the Planning Commission has held a public hearing on the amendment and recommended approval of the proposed amendment to the codified ordinance at its meeting on March 16, 2026.

NOW, THEREFORE, BE IT ORDAINED by council for the city of New Albany, counties of Franklin and Licking, State of Ohio, that:

Section 1. Portions of Codified Ordinance Chapter 1159.11 shall be amended as set forth in Exhibit A, which depicts these amendments in colored ink.

Section 2. It is hereby found and determined that all formal actions of this council concerning and relating to the adoption of this legislation were adopted in an open meeting of council, and that all deliberations of the council and or any of its committees that resulted in such formal action were in meetings open to the public, in compliance with Section 121.22 of the Ohio Revised Code.

Section 3. Pursuant to Article 6.07(B) of the New Albany Charter, this ordinance shall become effective thirty (30) days after adoption.

CERTIFIED AS ADOPTED this 05 day of May, 2026.

Attest:

Sloan T. Spalding
Mayor

Jennifer H. Mason
Clerk of Council

Approved as to form:

Benjamin S. Albrecht
Interim Law Director

Legislation dates:

Prepared:	04/06/2026
Introduced:	04/21/2026
Revised:	
Adopted:	05/05/2026
Effective:	06/04/2026

CHAPTER 1159 PUD PLANNED UNIT DEVELOPMENT DISTRICT¹

1159.11 RECORDING AND TRANSFER.

(a) Final Plat: When a final plat is approved by Council, the owner shall file and record the same in the Office of the County Recorder within twelve (12) months unless such time is, for good cause shown, extended by resolution of Council. If not recorded within this time, the approval of Council shall become null and void.

(b) Final Development Plan: If construction is not begun within two (2) years of approval of the Final Development Plan, all approvals and permits shall be invalidated and canceled. Original tracings will become the permanent record of the County Recorder. One copy of this tracing, reproduced on mylar, showing the date and place of recording, shall be supplied by the owner to Council as local public records. Such two (2) year period may be extended by the Commission for good cause. The applicant may request a one-time timeframe extension for one (1) year by the Commission, if the applicant has documented in-writing one of the following: a) Financial issues that would alter the expected FDP timeline; b) Delay in acquiring a required building or utility permit necessary to carry out the provisions of the FDP; c) Presence of an environmental or other public safety issues; d) Other unique reasons deemed as permissible by the Commission.

(Ord. 44-97. Passed 12-16-97; Ord. 25-2007. Passed 7-10-07.)

¹Cross reference(s)—District established - see P. & Z. 1125.01



RESOLUTION R-11-2026

A RESOLUTION AUTHORIZING THE CITY MANAGER TO ENTER INTO A CONSTRUCTION MANAGER AT RISK CONTRACT WITH MESSER CONSTRUCTION CO. FOR THE PURPOSE OF PROVIDING PRE-CONSTRUCTION SERVICES FOR THE NEW ALBANY BEVELHYMER FACILITIES IMPROVEMENTS PROJECT

WHEREAS, New Albany City Council previously authorized funding for the planning, design, and construction of the New Albany Bevelhymer Facilities Improvements Project (the “Project”), and subsequently approved, via Resolution R-04-2026, the use of the Construction Manager at Risk (“CMR”) selection and delivery method; and

WHEREAS, the CMR process utilizes a qualification-based, two-step competitive selection process, consisting of a Request for Qualifications (“RFQ”) followed by a Request for Proposals (“RFP”); and

WHEREAS, five (5) firms submitted Statements of Qualifications in response to the RFQ, of which the city’s selection committee determined that three (3) firms were most qualified and were invited to participate in the RFP phase; and

WHEREAS, three (3) firms submitted proposals in response to the RFP and were evaluated based on technical qualifications, project approach, and fee proposals; and

WHEREAS, following evaluation of the proposals and interviews, the Selection Committee determined that Messer Construction Co. (“Messer”) is the most qualified firm and best value to serve as the Construction Manager at Risk for the Project; and

WHEREAS, the city will be utilizing a modified American Institute of Architects (“AIA”) Construction Manager at Risk agreement, the terms of which are currently being finalized; and

WHEREAS, in the event consensus cannot be reached as to the terms of the CMR agreement, the city may elect to proceed with the second-ranked firm, which did not propose any contract modification; and

WHEREAS, execution of the CMR agreement will enable Messer to provide pre-construction services, including cost estimating, constructability review, scheduling, and coordination, as well as development of a proposed Guaranteed Maximum Price (GMP) for the Project; and

WHEREAS, once the GMP is established, council will be presented with additional legislation authorizing the city manager to enter into a Guaranteed Maximum Price Amendment to the contract, at which time construction will be authorized; and

WHEREAS, prior to council's approval of the GMP Amendment, the city may terminate the CMR contract without cause; and

WHEREAS, this legislation also authorizes the city manager to enter into all additional Project-related contracts, such as construction inspection, testing, and legal services, within the Project budget previously approved by council.

NOW, THEREFORE, BE IT RESOLVED by Council for the City of New Albany, counties of Franklin and Licking, State of Ohio, that:

Section 1. Council hereby finds that for the reasons set forth in the "WHEREAS" clauses herein, the city manager is hereby authorized to enter into a Construction Manager at Risk contract with Messer Construction Co. as the apparent successful offeror, or, in the event acceptable contract terms cannot be reached, with the second ranked firm.

Section 2. At any time prior to council's approval of a Guaranteed Maximum Price Amendment to the contract, the city may terminate the CMR contract without cause.

Section 3. The city manager is also hereby authorized to enter into additional Project-related contracts which are within the Project budget established by council.

Section 4. It is hereby found and determined that all formal actions of this council concerning and relating to the adoption of this legislation were adopted in an open meeting of council, and that all deliberations of council and any of its committees that resulted in such formal action were in meetings open to the public, in compliance with all applicable legal requirements, including Section 121.22 of the Ohio Revised Code.

Section 5. Pursuant to Article 6.07(a) of the New Albany Charter, this resolution shall become effective immediately upon adoption.

CERTIFIED AS ADOPTED this 05 day of May, 2025.

Attest:



Sloan T. Spalding
Mayor



Jennifer H. Mason
Clerk of Council

Approved as to form:



Benjamin S. Albrecht
Law Director

Legislation dates:

Prepared: 04/24/2026

Introduced: 05/05/2026

Revised:

Adopted: 05/05/2026

Effective: 05/05/2026



RESOLUTION R-12-2026

A RESOLUTION TO AUTHORIZE THE CITY MANAGER TO ADVERTISE, BID, AWARD AND EXECUTE ALL AGREEMENTS AND CONTRACTS RELATED TO THE 2026 CITY OF NEW ALBANY STREET IMPROVEMENT PROJECT

WHEREAS, New Albany City Council desires to proceed with general roadway maintenance such as asphalt overlay, crack seal, curb, and curb ramp replacements as needed within the city, and

WHEREAS, the city will advertise for and award bids in accordance with the codified ordinances of New Albany and the Ohio Revised Code, and

WHEREAS, the engineer's construction cost estimate for the project is \$4.3 million; and

WHEREAS, funding for this work is provided in the 2026 capital improvements budget.

NOW, THEREFORE, BE IT RESOLVED by Council for the City of New Albany, Counties of Franklin and Licking, State of Ohio, that:

Section 1. The city manager is hereby authorized and directed to advertise, bid, award, and execute all agreements and contracts related to the 2026 City of New Albany Street Improvement Project.

Section 2. It is hereby found and determined that all formal actions of this council concerning and relating to the adoption of this legislation were adopted in an open meeting of the council, and that all deliberations of the council and or any of its committees that resulted in such formal action were in meetings open to the public, in compliance with all legal requirements, including Section 121.22 of the Ohio Revised Code.

Section 3. Pursuant to Article 6.07(A) of the New Albany Charter, this resolution shall take effect upon adoption.

CERTIFIED AS ADOPTED this 05 day of May, 2026.

Attest:



Sloan T. Spalding
Mayor



Jennifer H. Mason
Clerk of Council

Approved as to form:



Benjamin S. Albrecht
Law Director

Legislation dates:

Prepared: 04/24/2026

Introduced: 05/05/2026

Revised:

Adopted: 05/05/2026

Effective: 05/05/2026